

(12) UK Patent Application (19) GB (11) 2 156 588 A

(43) Application published 9 Oct 1985

(21) Application No 8506950

(22) Date of filing 18 Mar 1985

(30) Priority data

(31) 8404844 (32) 28 Mar 1984 (33) FR

(71) Applicant

Mektron France SA (France),
Zone Industrielle de Bellitourne, F-53200 Chateau
Gontier, France

(72) Inventors

Roger Meleard
Jean-Jacques Prioux

(74) Agent and/or Address for Service

Frank B Dehn & Co,
Imperial House, 15-19 Kingsway, London WC2B 6UZ

(51) INT CL⁴

H01H 13/70 13/26 13/52

(52) Domestic classification

H1N 818 825 826 849 654 700 705 747 854 BH
U1S 1727 1739 2028 2123 H1N

(56) Documents cited

GB A 2071420

(58) Field of search

H1N

(54) Membrane switch

(57) A membrane switch assembly includes a stationary membrane switch circuit layer (16), an insulating spacer (28) or separator on the stationary membrane layer having at least one opening therethrough (30) and a movable membrane layer switch circuit on the other side of the spacer having at least one snap-action tactile element (22) extending upwardly therefrom. The stationary membrane layer has electrical conductors (16) thereon arranged in a geometrical pattern and cooperating with the openings (30) in the separator layer (28) to define an array of unique switch and circuit locations. The movable layer has a conductive contact surface 26 located on the flat surface thereof along the periphery of a tactile element (22), preferably as an annular ring, or as segments.

FIG. 3

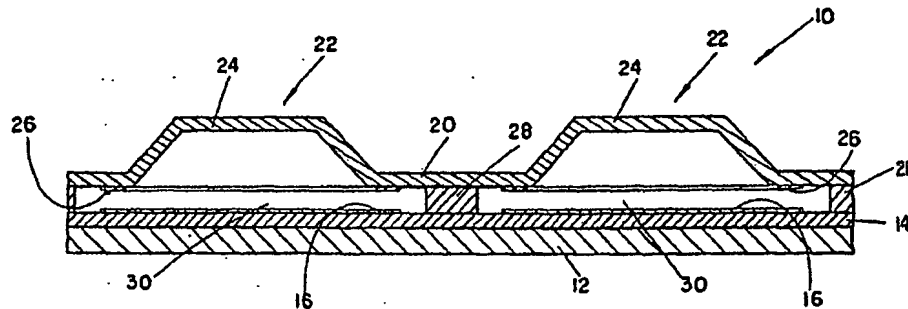

GB 2 156 588 A

The drawings originally filed were informal and the print here reproduced is taken from a later filed formal copy.

1/3

2150093

FIG. 1

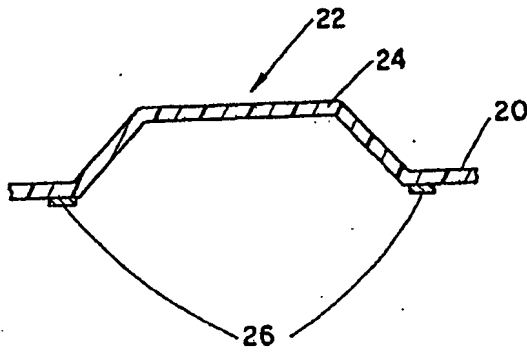

FIG. 2

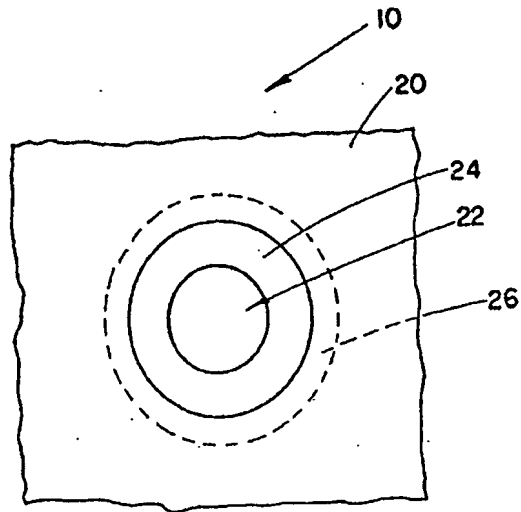

FIG. 2A

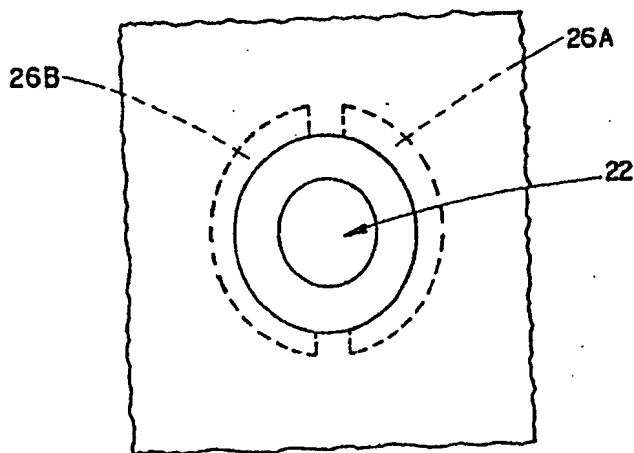
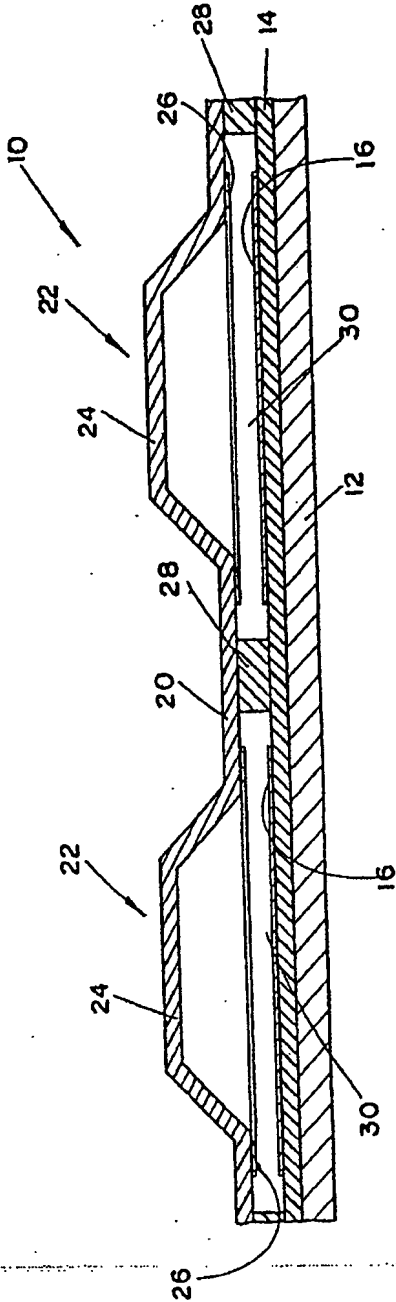

FIG. 3



SPECIFICATION

Membrane switch

5 This invention relates to tactile membrane keyboards. More particularly, this invention relates to tactile membrane keyboards having a strong tactile snap effect and an extremely long functional life.

10 Tactile membrane keyboards have found increasing use and acceptance in many commercial and domestic applications. Thus by way of example only, the keyboard has found utility in retail outlets, airline terminals, fast-food restaurant terminals, data terminals, calculators, and any other apparatus wherein digital input is necessary.

15 A conventional keyboard includes an array of keys which may be individually actuated to close a pair of contacts of an electrical circuit associated with each of the keys. It is often considered desirable to provide for tactile feedback so that, when the keys are pressed by the finger of a person operating the keyboard, the keys "snap" and force discontinuity is transmitted to the finger of the user indicating that the key has been actuated and an electrical signal thus generated in the circuit associated with the key.

20 A typical membrane type keyboard having tactility as described above is comprised of a membrane switch assembly which includes a bottom stiffener layer, a stationary membrane switch circuit layer on the stiffener, an insulating spacer or separator on the stationary membrane layer, and an active membrane switch circuit layer on the other side of the spacer. This active membrane layer is often comprised of a plurality of tactile snap-action elements such as domes which extend upwardly therefrom away from the lower stationary membrane layer. Both the stationary and active membrane layers have electrical conductors thereon (formed by printed circuit techniques such as conductive ink) arranged in a desired pattern and cooperating with holes or openings in the separator layer to define an array of unique switch and circuit locations. The application of an appropriate force to a switch site (i.e., tactile dome) on the upper surface of the active layer causes the active layer and its particular switch component to make mechanical and electrical contact through the appropriate hole in the spacer with the circuit pattern on the fixed or passive layer of the membrane.

25 Conventional prior art tactile membrane keyboards have a problem of a lack of reliability and uniformity in the operational or functional lifespan (i.e., number of actuations before failure) of tactile domes. To a great extent, this problem appears to result from a degradation or breakdown of the conductive ink on the active membrane layer. It is hypothesized that stress and fatigue from the con-

tinued flexing or actuating of the tactile dome eventually causes the degradation of the conductive material (e.g., ink) located on the inside surface of the dome. Thus, after such a breakdown, the tactile dome, which serves as the contact medium for conventional keyboards, will no longer effect adequate electrical contact. Breakdown of the conductive materials on the contact surface of the active layer either require the keyboard to be discarded or will create undesirably increased maintenance, replacement and labor costs for repair. Accordingly, a tactile membrane keyboard which not only retains adequate tactile (snap-action) feedback, but also has an improved or extended operating life would be highly desirable and advantageous.

70 In accordance with the present invention, there is provided a membrane switch comprising a first circuit sheet, said first circuit sheet having at least a first sheet of insulating material with first electrically conductive contact means thereon, a said second sheet having a second sheet of insulating material, at least one tactile element formed in and extending from said second sheet, said second sheet of insulating material defining a flat surface at the base of said tactile element, second-electrically conductive contact means on said flat surface about the periphery of said tactile element, spacer means between said first and second circuit sheet, said spacer means having a plurality of openings therein whereby said tactile element is actuatable under an applied force to move said second conductive contact means through said opening and into electrical contact with said first conductive contact means.

75 As in the prior art keyboards, the lower stationary membrane layer has a contact area of electrical conductors (e.g., copper traces or conductive ink) thereon arranged in a pattern and cooperating with holes in the separator layer to define an array of unique switch and circuit locations. Unlike the prior art, a novel improvement of the present invention lies in the positioning and structure of the contact surface of the active layer. This novel contact surface, which may be comprised of conductive ink or other conductive material, is applied to the active layer, around the periphery of the base of a dome on the flat surface of the active layer, preferably as an annular ring. Thus, as no part of the upper contact ring surface is adhered to the flexing surface of the dome as in the prior art, the conductive material comprising the contact surface will not be subject to the previously discussed stress or fatigue and resultant breakdown when the dome is repeatedly actuated over a long period of time. The tactile membrane keyboard of the present invention, therefore, exhibits a markedly improved and extended operating life which in turn, provides improved efficiency and greater reliability and

economy to the keyboard purchaser and manufacturer. Note that the present invention requires the use of less conductive ink than in the prior art and therefore reduced manufacturing costs.

In order to accomplish this modified annular contact structure along the periphery of the domes, the diameter of the openings in the spacer or separator is increased relative to conventional keyboards. Similarly, the contact area of the lower stationary layer is correspondingly increased to equal that of the openings. Thus, sufficient room is provided for the annular contact rings on the active layer so that, upon actuation of the dome, the annular ring will have an open path to effect contact with the electrical conductors on the stationary layer. The particular structural arrangement of the present invention provides electrical contact prior to the dome having travelled its full course, with the full travel of the dome and snap action or tactile feedback telling the operator that switch actuation has occurred.

Various modifications and embodiments of the tactile membrane keyboard of the present invention include segmenting one or both switch contact surfaces in order to permit multiple parallel contacts on both the upper and lower circuit layers. Also the present invention is equally applicable to a multiplicity of dome configurations including, but not limited to, oval domes and ramp-shaped domes. Finally, the absence of conductive material along the inside surface of the snap-action dome permits the incorporation of back-lighting, i.e., illumination from beneath the keys.

The above-discussed and other advantages of the present invention will be apparent to and understood by those skilled in the art from the following detailed description and drawings.

Referring now to the drawings, wherein like elements are numbered alike in the several figures:

Figure 1 is a partial cross-sectional elevation view of the upper portion of an individual tactile membrane element in accordance with the present invention.

Figure 2 is a plan view of the tactile dome of Fig. 1 in accordance with the present invention.

Figure 2A is a view similar to Fig. 2 of a modified construction.

Figure 3 is a cross-sectional elevation view showing a tactile membrane keyboard assembly in accordance with the present invention.

Referring to the Figures, a portion of a keyboard in accordance with the present invention is shown. In the Figures, one or two key locations are shown, but it will be understood that an entire keyboard is made up of a monolithic membrane circuit structure comprised of any number of individual tactile domes or keys, the specific number being

determined by the requirements of the particular keyboard and application.

A two key portion of a monolithic membrane keyboard or circuit array 10 is shown in Fig. 3. The monolithic membrane keyboard or switch structure includes a bottom stiffener sheet or rigidizing layer 12 which may be a plastic or metal sheet with stiffness and flatness equivalent to aluminum 6061 alloy of approximately 0.5 mm thick. Stiffener 12 serves to support and maintain in planar condition a fixed or passive layer circuit sheet of the key switch assembly which consists of a lower insulating layer or sheet 14, preferably of Mylar polyester film, and a lower circuit pattern 16 formed thereon. This fixed or passive key switch layer or circuit sheet is adhesively bonded to stiffener 12. Insulating layer 14 may be of any desired thickness, preferably between 0.05 mm to 0.18 mm and the conductive pattern thereon may be formed by any known printed circuit technique, such as by printing with a conductive ink, printing or etching a conductive metal foil, etc. Preferably, the conductive pattern 16 should be reasonably thin (on the order of 0.01 to 0.05 mm in thickness, and preferably about 0.025 mm thick).

A movable or active switch layer or upper circuit sheet is positioned above the lower circuit pattern 16. The movable or active switch layer comprises an upper insulating layer 20, e.g. Mylar. The upper insulating layer 20 has an array of snap-action protrusions or tactile elements 22 in the shape of an arcuate dome 24 of truncated cone shape having a flattened top surface. As mentioned, the present invention is equally applicable to tactile domes of other shapes including, but not limited to, semispherical domes, oval-shaped domes, ramp domes, etc. The insulating layer 20 of the active switch layer has a printed circuit conductor or contact surface 26 having the shape of an annular ring and formed by any known printed circuit technique (e.g., conductive ink). This annular ring-shaped contact surface 26 runs around the outer periphery of the dome 24 base and is adhesively or otherwise bonded to the flat surface of the active switch layer.

An insulating spacer or separator layer 28 having a plurality of openings 30 may be adhesively or otherwise fixed in position on one side to the stationary layer on which the lower circuit pattern 16 is located, and on the other side to the upper insulating layer 20. The total thickness of the spacer 28 may be used to adjust the distance between the upper conductor 26 and the lower circuit pattern 16. The opening 30 in spacer 28 must be larger than the diameter or outer dimensions of conductor pattern 26 so as to allow the dome 24 to snap through and deflect pattern 26 into contact with the circuit pattern 16 in order to achieve electrical contact between the

- of said tactile element,
spacer means between said first and second
circuit sheet,
said spacer means having a plurality of
5 openings therein whereby said tactile element
is actuatable under an applied force to move
said second conductive contact means
through said opening and into electrical con-
tact with said first conductive contact means.
- 10 2. A membrane switch as claimed in
Claim 1, wherein said tactile element is a
snap-action dome.
3. A membrane switch as claimed in
Claim 2, wherein said snap-action dome has
15 an arcuate shape with a flat top.
4. A membrane switch as claimed in any
one of Claims 1 to 3, wherein said second
conductive contactor means has an annular
shape.
- 20 5. A membrane switch as claimed in
Claim 4, wherein said first conductive con-
tactor means has an annular shape correspond-
ing to said second conductive contactor
means.
- 25 6. A membrane switch as claimed in any
one of Claims 1 to 5, wherein said first and
second conductive contactor means are com-
prised of a conductive ink.
7. A membrane switch as claimed in any
30 one of Claims 1 to 6, wherein said first and
second conductive contactor means are seg-
mented thereby permitting multiple parallel
contacts on said upper and lower circuit sheet
means.
- 35 8. A membrane switch as claimed in any
one of Claims 1 to 7, including a stiffening
sheet in supporting attachment to said lower
circuit sheet means.
9. A membrane switch as claimed in any
40 one of Claims 1 to 8, wherein said tactile
element is free of electrically conductive ma-
terial within the periphery of said tactile ele-
ment, whereby said tactile element is suitable
for backlighting.
- 45 10. A membrane switch substantially as
hereinbefore described and as illustrated in
the accompanying drawings.

AL MINISTERO DELL'INDUSTRIA DEL COMMERCIO E DELL'ARTIGIAN.
 UFFICIO CENTRALE BREVETTI - ROMA
 DOMANDA DI BREVETTO PER INVENZIONE INDUSTRIALE DEPOSITO RISERVATO ANTICIPATO

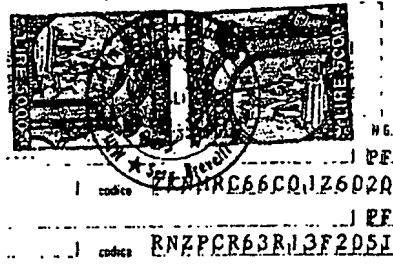

A. RICHIEDENTE (1)

1) Dato di nascita | ZUKIN MARCIO
 Residenza | MILANO VIA POPOLI UNITI 20
 2) Dato di nascita | RANZANI PAOLO CARLO
 Residenza | MILANO VIA FORNARI 10

B. RAPPRESENTANTE DEL RICHIEDENTE PRESSO L'U.C.B.

nome cognome | //
 denominazione studio di appartenenza | //
 via | // città | // cap | // (prov) | //

C. DOMICILIO ELETTIVO DESTINATARIO | RANZANI PAOLO CARLO C/O F.LLI RANZANI
 via | SALVO D'ACQUISTO città | SIZIANO cap | 27010 (prov) | PV

D. TITOLO classe proposta (eur/usc) | // gruppo/sottogruppo | //
 TASTIERA A RETROAZIONE TATTILE A VIBRAZIONE

ANTICIPATA ACCESSIBILITÀ AL PUBBLICO: SI NO SE ISTANZA: DATA // // // N° PROTOCOLLO // //

E. INVENTORI DESIGNATI
 1) ZUKIN MARCIO
 2) RANZANI PAOLO CARLO

F. PRIORITÀ

nazione o organizzazione	tipo di priorità	numero di domanda	data di deposito	allegato SR	SCIoglimento RISERVE Data N° Protocollo
1)					
2)					

G. CENTRO ABILITATO DI RACCOLTA COLTURE DI MICRORGANISMI, denominazione

H. ANNOTAZIONI SPECIALI

DOCUMENTAZIONE ALLEGATA

N. es.	Doc.	Descrizione	SCIoglimento RISERVE Data N° Protocollo
1)	1) [1] [PROV] n. pag 108	riassunto con disegno principale, descrizione e rivendicazioni (obbligatorio 1 esemplare)	
2)	2) [1] [PROV] n. tav 11	disegno (obbligatorio se citato in descrizione, 1 esemplare)	
3)	3) [1] [RS]	lettere d'incarico, procura o riferimento procura generale	
4)	4) [1] [RS]	designazione inventore	
5)	5) [1] [RS]	documenti di priorità con traduzione in italiano	
6)	6) [1] [RS]	autorizzazione o atto di cessione	
7)	7) [1]	nominativo completo del richiedente	

8) attestato di versamento totale lire L. 159.000 (centocinquantanovemila) obbligatorio
 9) marche da bollo per attestato di brevetto di lire L. 10.000 (diecimila) obbligatorio

COMPILATO IL 109/112/1991 FIRMA DEL(1) RICHIEDENTE (1) *Luigi Zukin*
 CONTINUA SI/NO NO

DEL PRESENTE ATTO SI RICHIEDE COPIA AUTENTICA SI/NO NO

UFFICIO PROVINCIALE IND. COMM. ART. DI MILANO codice 05
 VERBALE DI DEPOSITO NUMERO DI DOMANDA L. MI 91 A 00 3315 Reg. A
 L'anno millenovecento | Novantuno | il giorno | Undici | del mese di | Dicembre

di(1) richiedente(s) sopraindicato(i) ha(hanno) presentato a me sottoscritto la presente domanda, corredata di n. // fogli aggiuntivi per la concessione del brevetto soprariportata.

L. ANNOTAZIONI VARIE DELL'UFFICIALE ROGANTE

IL DEPOSITANTE

Luigi Zukin



L'UFFICIALE ROGANTE
 Polignoli A.

RIASSUNTO INVENZIONE CON DISEGNO PRINCIPALE, DESCRIZIONE E RIVENDICAZIONE

NUMERO DOMANDA L 10.91.7.003315 REG. B
NUMERO BREVETTO L

DATA DI DEPOSITO 11/11/1971
DATA DI RILASCIO 11/11/1971

D. TITOLO

L TASTIERA A RETROAZIONE TATTILE A VIBRAZIONE.....
L
L
L

L. RIASSUNTO

Tastiera di comando per apparecchiature elettriche od elettroniche in cui la retroazione dell'avvenuto comando viene inoltrata allo operatore mediante vibrazione del tasto stesso.

M. DISEGNO



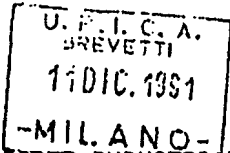

MI 91 A/033 15

Marcio Zukin

DESCRIZIONE DI INVENZIONE INDUSTRIALE

Descrizione dell'INVENZIONE INDUSTRIALE dal
titolo: "TASTIERA A RETROAZIONE TATTILE A
VIBRAZIONE" a nome dei Sigg.

Zukin Marcio nato a Rio De Janeiro -Brasile- il
01/03/1966 residente a Milano in via Popoli Uniti
20

Ranzani Paolo nato a Milano il 13/10/1963
residente a Milano in via Fornari 10

RIASSUNTO

Tastiera di comando per apparecchiature
elettriche/elettroniche in cui la retroazione
dell'avvenuto comando, viene inoltrata
all'operatore mediante vibrazione del tasto
stesso.

STATO ATTUALE DELLA TECNICA

Sono note le tastiere o pulsantiere di comando che
quotidianamente vengono azionate nelle piu'
diversificate applicazioni: calcolatrici,
telefoni, ascensori, distributori automatici,
elettrodomestici etc.

Le attuali tastiere presentano tipologie
costruttive variabili anche in funzione della
applicazione; si hanno pertanto tastiere a

Luca di Fulvia

microinterruttori, a membrana, capacitive etc.

Elemento essenziale dell'apparecchiatura e' un contatto, meccanico od elettronico, che viene chiuso, ovvero messo in conduzione, quando il tasto viene premuto dall'operatore.

L'informazione che il tasto e' stato effettivamente premuto puo' pervenire all'operatore in diversi modi: rumore meccanico del tasto, segnalazione acustica, segnalazione luminosa, innesco delle operazioni comandate dal tasto, etc.

In applicazioni di largo consumo od in ambienti industriali particolarmente ostili, si preferisce utilizzare tastiere a membrana o capacitive per la loro maggiore resistenza meccanica ed alla penetrazione di agenti esterni come polvere, umidita', trucioli di lavorazione.

Tali tastiere non danno una retroazione "meccanica" a causa della loro tecnologia costruttiva, si deve pertanto ricorrere alla segnalazione acustica o luminosa.

Nel caso in cui l'operatore sia non udente o non vedente o comunque si trovi in ambienti rumorosi o malamente illuminati, egli non puo' definire con

certezza l'avvenuto comando.

Manfred Z...

Il ritrovato in oggetto elimina o riduce i suddetti inconvenienti risolvendo anche completamente alcuni problemi come qui di seguito illustrato.

DESCRIZIONE DEL RITROVATO

Secondo il ritrovato si prevede una risposta all'operatore mediante la vibrazione del tasto premuto.

La retroazione agisce pertanto sul tatto dell'operatore, lasciando liberi, se efficienti, gli altri sensi.

Secondo una struttura preferenziale, il ritrovato si presenta come una normale tastiera a membrana sotto alla quale vengono applicati dei trasduttori piezoelettrici, che, eccitati ad una opportuna frequenza, mettono in vibrazione il tasto stesso.

In una variante si prevede che lo stesso trasduttore piezoelettrico funzioni contemporaneamente anche da tasto, in quanto esso genera una tensione proporzionale alla sollecitazione meccanica applicata.

Allo scopo di rendere idoneo il ritrovato anche ad applicazioni già esistenti, il trasduttore

M. C. Z. 1/68

potrebbe essere posizionato anche sul lato anteriore del tasto.

VANTAGGI

Sono evidenti i vantaggi del ritrovato.

Con una tastiera avente aspetto esteriore uguale a quello dei modelli esistenti, si allarga la possibilita' di uso di certe apparecchiature anche a persone handicappate o l'uso di apparecchiature in ambienti particolarmente ostili.

All'operatore non viene richiesta nessuna attenzione particolare e l'uso del ritrovato non presenta complicazioni aggiunte.

Ovviamente sono innumerevoli le varianti possibili.

Ad esempio al posto di un trasduttore piezoelettrico se ne puo' usare uno di tipo magnetodinamico, o di tipo magnetostriativo.

Pertanto deve essere inteso che nella domanda di privativa sia compresa ogni equivalente applicazione dei concetti ed ogni equivalente prodotto attuato e/o operante secondo una o piu' qualsiasi delle caratteristiche indicate nelle seguenti:

RIVENDICAZIONI

Manca di Zink

- 1) Tastiera a retroazione caratterizzata da cio' che la retroazione viene inviata all'operatore mediante azione vibratoria del tasto stesso.
- 2) Tastiera a retroazione come alla rivendicazione 1), caratterizzata da cio' che la vibrazione inizia dopo che il tasto e' stato effettivamente premuto.
- 3) Tastiera a retroazione come alle rivendicazioni 1) e 2), caratterizzata da cio' che la vibrazione viene generata da un trasduttore piezoelettrico.
- 4) Tastiera a retroazione come alle rivendicazioni da 1) a 3), caratterizzata da cio' che il trasduttore piezoelettrico viene pilotato da un circuito elettronico.
- 5) Tastiera a retroazione come alle rivendicazioni da 1) a 4), caratterizzata da cio' che la tastiera ha forme usuali e pertanto e' di uso istintivo.
- 6) Tastiera a retroazione come alle rivendicazioni da 1) a 5), caratterizzata da cio' che il trasduttore puo' essere anche di tipo differente.
- 7) Tastiera a retroazione come alle rivendicazioni da 1) a 6), caratterizzata da cio' che il trasduttore puo' essere posizionato anche sulla faccia anteriore della tastiera.
- 8) Tastiera a retroazione come alle rivendicazioni da 1) a 7), caratterizzata da cio' che il

Richard Zient

trasduttore stesso puo' fungere da tastiera.

9) Tastiera a retroazione come alle rivendicazioni da 1) a 8); caratterizzata da cio'che l'innesco della vibrazione puo' essere determinato dalla effettiva attuazione della operazione legata alla pressione del tasto.

10) Tastiera a retroazione come alle rivendicazioni da 1) a 9), caratterizzata da cio'che la frequenza di vibrazione del tasto puo' essere differenziata per indicare diversi tipi di azione.

11) Tastiera a retroazione come alle rivendicazioni da 1) a 10), caratterizzata da cio'che il trasduttore sia applicato alla tastiera mediante incollaggio od altro mezzo.

12) Tastiera a retroazione come alle rivendicazioni da 1) a 11), caratterizzata da cio'che il circuito elettronico di pilotaggio del trasduttore sia montato su una scheda separata.

13) Tastiera a retroazione come alle rivendicazioni da 1) a 12), caratterizzata da cio'che il circuito elettronico di pilotaggio venga integrato nel trasduttore stesso.

14) Tastiera a retroazione come alle

Manuscript

rivendicazioni da 1) a 13), caratterizzata da
ciò che il sistema possa essere applicato anche su
tastiere preesistenti.

Il tutto sostanzialmente come descritto ed
illustrato e per gli scopi specificati.

Manuscript



DESCRIPTION OF AN INDUSTRIAL INVENTION

Description of the INDUSTRIAL INVENTION having the title: "KEYBOARD WITH VIBRATING TACTILE FEEDBACK" to

Mr Zukin Marcio born in Rio De Janeiro – Brazil – on 01/03/1966 resident in Milan at via Popoli Uniti 20

Mr Ranzani Paolo born in Milan on 13/10/1963 resident in Milan at via Fornari 10

ABSTRACT

Command keyboard for electrical/electronic apparatuses in which the feedback of a command that has occurred is transmitted to the operator through vibration of the button itself.

BACKGROUND OF THE INVENTION

Keyboards or keypads are known that are actuated daily in the most different applications: calculators, telephones, lifts, cash machines, domestic appliances, etc.

Current keyboards have variable embodiments also according to the application; therefore there are microswitch, membrane, capacitative keyboards, etc.

An essential element of the apparatus is a contact, mechanical or electronic, which is closed, i.e. made to conduct, when the button is pressed by the operator.

The operator can be informed that the button has actually been pressed in different ways: mechanical noise of the button, acoustic signal, light signal, triggering of the operations commanded by the button, etc.

In widely used applications or in particularly hostile industrial environments, it is preferred to use membrane or capacitive keyboards due to their greater mechanical strength and the penetration of impurities like dust, humidity and processing chips.

Such keyboards do not give "mechanical" feedback due to their constructive technology and therefore acoustic or light signals must be used.

In the case in which the operator is deaf or blind or in any case is in noisy or poorly lit environments, he cannot be certain of whether a command has occurred.

The invention in object eliminates or reduces the aforementioned drawbacks also completely solving some problems as illustrated hereafter.

DESCRIPTION OF THE INVENTION

According to the invention, a response to the operator through the vibration of the pressed button is foreseen.

The feedback therefore acts on the operator's sense of touch, leaving the other senses free, if they work.

According to a preferential structure, the invention is in the form of a normal membrane keyboard under which piezoelectric transducers are applied that, excited at a suitable frequency, make the button itself vibrate.

In a variant it is foreseen for the same piezoelectric transducer to simultaneously operate as a button, since it generates a voltage proportional to the mechanical stress applied.

In order to make the invention also suitable for applications that already exist, the transducer could also be positioned on the front side of the button.

ADVANTAGES

The advantages of the invention are clear.

With a keyboard having the same appearance as existing models, the possibility of using certain apparatuses is extended to handicapped people or it becomes possible to use apparatuses in particularly hostile environments.

The operator does not have to pay any special attention and the use of the invention has no additional complications.

Obviously, the possible variants are numerous. For example, instead of a piezoelectric transducer, a magnetodynamic or magnetostrictive transducer can be used.

Therefore, it should be understood that the patent application covers any equivalent application of the concepts and any equivalent product made and/or operating according to any one or more of the characteristics indicated in the following:

CLAIMS

- 1) Keyboard with feedback characterized in that the feedback is sent to the operator through vibration of the button itself.
- 2) Keyboard with feedback according to claim 1), characterized in that the vibration begins after the button has actually been pressed.
- 3) Keyboard with feedback according to claims 1) and 2), characterized in that the vibration is generated by a piezoelectric transducer.
- 4) Keyboard with feedback according to claims 1) to 3), characterized in that the piezoelectric transducer is controlled by an electronic circuit.
- 5) Keyboard with feedback according to claims 1) to 4), characterized in that the keyboard is the normal shape and is therefore instinctive to use.
- 6) Keyboard with feedback according to claims 1) to 5), characterized in that the transducer can also be of a different type.
- 7) Keyboard with feedback according to claims 1) to 6), characterized in that the transducer can also be positioned on the front face of the keyboard.
- 8) Keyboard with feedback according to claims 1) to 7), characterized in that the transducer itself can act as a keyboard.
- 9) Keyboard with feedback according to claims 1) to 8), characterized in that the triggering of the vibration can be brought about by the actual actuation of the operation linked to the pressing of the button.
- 10) Keyboard with feedback according to claims 1) to 9), characterized in that the frequency of vibration of the button can be differentiated to indicate different types of action.
- 11) Keyboard with feedback according to claims 1) to 10), characterized in that the transducer is applied to the keyboard through gluing or another means.

12) Keyboard with feedback according to claims 1) to 11), characterized in that the electronic control circuit of the transducer is mounted on a separate board.

13) Keyboard with feedback according to claims 1) to 12), characterized in that the electronic control circuit is integrated in the transducer itself.

14) Keyboard with feedback according to claims 1) to 13), characterized in that the system can also be applied onto pre-existing keyboards.

All as substantially described and illustrated and for the specified purposes.

(19)日本国特許庁(JP)

(12)公開特許公報(A)

(11)特許出願公開番号

特開平5-304007

(43)公開日 平成5年(1993)11月16日

(51)Int.Cl.*	識別記号	庁内整理番号	F I	技術表示箇所
H 0 1 C 10/10	A			
H 0 1 H 13/12		7250-5G		
	13/52	Z 4235-5G		

審査請求 未請求 請求項の数1(全 4 頁)

(21)出願番号	特願平4-108250	(71)出願人	000158840 鬼怒川ゴム工業株式会社 千葉県千葉市稲毛区長沼町330番地
(22)出願日	平成4年(1992)4月28日	(72)発明者	田波 史郎 千葉県千葉市稲毛区長沼町330番地 鬼怒川ゴム工業株式会社内
		(72)発明者	池田 隆 千葉県千葉市稲毛区長沼町330番地 鬼怒川ゴム工業株式会社内
		(74)代理人	弁理士 志賀 富士弥 (外3名)

(54)【発明の名称】 感圧スイッチ

(57)【要約】

【目的】 小さな加圧力を瞬間的に加えるだけで感圧導電ゴムの抵抗値を急激に低下させる。

【構成】 感圧導電ゴム4を断面逆凹形状に形成してつぶれやすくする。感圧導電ゴム4のつぶれ変形に伴って、電極2、3との間の接触面積が増大しつつ感圧導電ゴム4自体の通電抵抗が急激に低下する性質を利用して、電極2、3同士の間のスイッチング作用を行わせる。

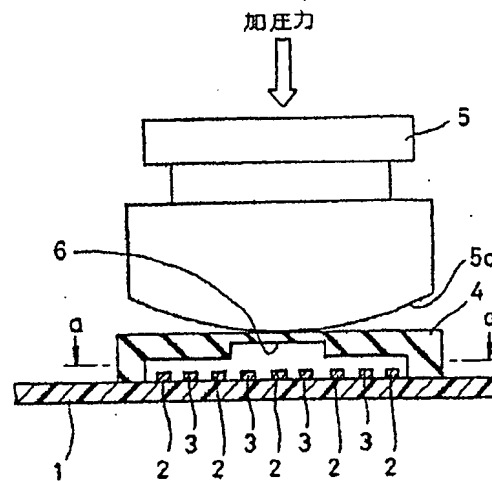

- 1 : フリント基板
- 2 : プラス電極
- 3 : マイナス電極
- 4 : 感圧導電ゴム

【特許請求の範囲】

【請求項1】 陽極および陰極のうち少なくとも一方の電極が設けられた基板上に感圧導電ゴムを配置してなり、この感圧導電ゴムを加圧することにより、該感圧導電ゴム自体の圧縮変形に伴う抵抗変化によって感圧導電ゴムを可動接点として一方の電極と他方の電極との間のスイッチング作用を行わせるようにした感圧スイッチであって、

前記感圧導電ゴムの無加圧状態において、この感圧導電ゴムと前記一方の電極とが非接触となるように感圧導電ゴムを断面逆凹形状に形成したことを特徴とする感圧スイッチ。

【発明の詳細な説明】

【0001】

【産業上の利用分野】本発明は、感圧導電ゴムの加圧に伴う抵抗変化を利用してスイッチング作用を行わせるようにした感圧スイッチに関する。

【0002】

【従来の技術】感圧導電ゴムを用いた感圧スイッチとして、例えば特開昭52-5477号公報に示されているように、感圧導電ゴムにて形成された一方のシート電極の表面に多数の山形状の突起部を形成する一方、この突起部が形成されたシート電極の表面に導電布等からなる他方のシート電極を貼り合わせ、双方の電極を加圧した場合に、前記突起部の圧縮変形により両電極間の接触面積が増大するのに伴ってその通電抵抗が急激に小さくなる性質を利用して、両電極間のスイッチング作用を行わせるようにしたものが知られている。

【0003】

【発明が解決しようとする課題】上記のような従来の感圧スイッチにおいては、ある程度まで加圧力を増大させると感圧導電ゴムの抵抗値が小さくなる傾向が認められるものの、微小な加圧力のもとでは抵抗値が無限大のままで何ら変化せず、スイッチング作用を行わせるのに必要な初期加圧力が比較的大きくなって好ましくない。

【0004】また、従来の構造では、特定の加圧力まで加圧した場合にその抵抗値が低下したとしても、抵抗値の低下落差すなわち加圧に伴う抵抗値の低下の度合が小さくて抵抗値の低下特性が緩慢となり、その低下特性のばらつき等を考慮すると感圧スイッチとしての機能を十分に発揮させることができない。

【0005】このようなことから、上記の抵抗値の低下特性を改善するために、前記突起部の高さを一つ置きに異ならしめた構造のものが特願平3-234523号として本出願人により提案されているが、このタイプのもものでは、図4に破線Aで示すように、先のものよりも急激な抵抗値の低下特性が認められるものの、抵抗値が低下し始めてから特定の値で飽和するまでの落差の面で必ずしも十分でないばかりでなく、その落差を得るための荷重変化が比較的大きいために実用性の上でなおも課題

を残している。

【0006】本発明は以上のような課題に着目してなされたもので、初期加圧力が小さく、しかも小さい加圧力変化のなかでより大きな抵抗値の落差が得られるようにした構造を提供しようとするものである。

【0007】

【課題を解決するための手段】本発明は、陽極および陰極のうち少なくとも一方の電極が設けられた基板上に感圧導電ゴムを配置してなり、この感圧導電ゴムを加圧することにより、該感圧導電ゴム自体の圧縮変形に伴う抵抗変化によって感圧導電ゴムを可動接点として一方の電極と他方の電極との間のスイッチング作用を行わせるようにした感圧スイッチであって、前記感圧導電ゴムの無加圧状態において、この感圧導電ゴムと前記一方の電極とが非接触となるように感圧導電ゴムを断面逆凹形状に形成したことを特徴としている。

【0008】

【作用】この構造によると、感圧導電ゴムを断面逆凹形状としたことによって、感圧導電ゴム自体がきわめて挽みやすくなり、感圧導電ゴムを加圧するにしたがって電極との接触面積を大きくして抵抗値を下げるとする感圧スイッチの要求特性とも合致する。したがって、電極に対する感圧導電ゴムの接触面積をより大きく確保でき、微小な加圧力でも抵抗値が急激に低下するとともに、加圧力をそれ以上増大させる必要もなくなる。

【0009】

【実施例】図1、2は本発明の一実施例を示す図で、キーボードスイッチに適用した場合の例を示している。

【0010】図1、2に示すように、プリント基板1上には、複数のプラス電極2とマイナス電極3とが互い違いとなるようにパターン印刷により全体としてくし形状に形成されている。前記プリント基板1の上には双方の電極2、3を覆うように感圧導電ゴム4がかぶせられ、その感圧導電ゴム4の上には所定曲率の円弧状の押圧面5を有するキートップ5が置かれている。

【0011】そして、前記感圧導電ゴム4は、無加圧状態において電極2、3と接触することがないように全体として断面逆凹形状に形成されているとともに、その内下面の中央部には凹陥部6が形成されており、これにより感圧導電ゴム4の中央部が最も薄肉に形成されている。

【0012】したがって、本実施例構造によれば、キートップ5を介して感圧導電ゴム4を加圧すると、図3に示すように感圧導電ゴム4が瞬時につぶれて、少なくとも複数のプラス電極2、2…のいずれかとマイナス電極3、3…のいずれかに接触する。

【0013】そして、上記のように感圧導電ゴム4がつぶれて変形すると、プラス電極2とマイナス電極3とが感圧導電ゴム4を可動接点として単に導通するだけでなく、感圧導電ゴム4の変形に伴ってその接触面積が増

大することで感圧導電ゴム4自体の通電抵抗が瞬時のうちに急激に低下する。これにより、プラス電極2とマイナス電極3との間に必要な電流が流れてスイッチング作用が行われる。

【0014】図4の実線Bは、上記実施例における感圧導電ゴム4の抵抗値の低下特性を示したもので、無加圧状態では感圧導電ゴム4の抵抗値が無限大であるのに対して、加圧するとその加圧力が30~40gf程度の範囲内で急激に低下し、それ以上の加圧力では抵抗値の低下度合が緩慢になるものの400gf程度までは緩やかに低下し、400gf以上の加圧力では零に近い抵抗値で安定化する。

【0015】つまり、本実施例によれば、微小な加圧力を加えるだけで感圧導電ゴム4の抵抗値が急激に低下することから初期加圧力が著しく小さくて済み、しかも抵抗値が一旦低下すればそれ以上加圧力を増やすことなしにスイッチング作用に必要な十分な抵抗値の落差が得られることになる。

【0016】また、感圧導電ゴム4が断面逆凹形状であって無加圧状態では空洞状となっていることから、感圧導電ゴム4のつぶれ変形によってスイッチング作用時の節度感も得られる。

【0017】なお、上記実施例では、プリント基板1上に陽陰双方の電極2、3を配置した場合の例を示しているが、プリント基板1上には陽陰いずれか一方の電極のみを配置し、他方の電極を感圧導電ゴム4の上側もしくは感圧導電ゴム4内に配置してもよい。

【0018】

【発明の効果】以上のように本発明によれば、感圧導電ゴムを可動接点として用いてこの感圧導電ゴムの加圧に伴う抵抗変化によりスイッチング作用を行うにあたり、感圧導電ゴムを断面逆凹形状に形成したことから、感圧導電ゴムがきわめてつぶれ変形しやすいものとなり、そのつぶれ変形時の接触面積を大きく確保できるようになり、微小な加圧力を瞬間的に加えるだけで大きな抵抗値の落差が得られるとともに、一旦抵抗値が低下し始めるとそれ以上加圧力を増大させる必要もなく、感圧スイッチとしての感度もしくは応答性が大幅に向上する。

【0019】また、感圧導電ゴムの加圧時にその感圧導電ゴム自体のつぶれ変形に伴う節度感も得られることから、感圧スイッチの操作性の面でもより良好なものとなる。

【図面の簡単な説明】

【図1】本発明の一実施例を示す無加圧時の断面図。

【図2】図1のa-a線に沿う断面図。

【図3】図1に示す感圧スイッチの加圧時の断面図。

【図4】上記感圧スイッチの加圧力（荷重）と抵抗値との関係を示す特性図。

【符号の説明】

- 1…プリント基板
- 2…プラス電極
- 3…マイナス電極
- 4…感圧導電ゴム
- 5…キートップ

【図1】

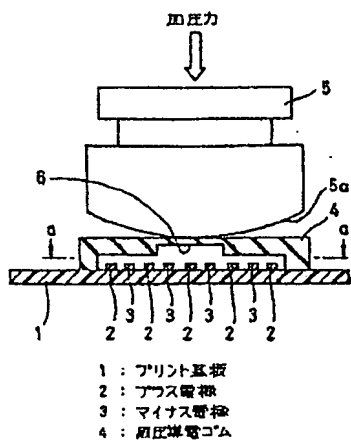

【図2】

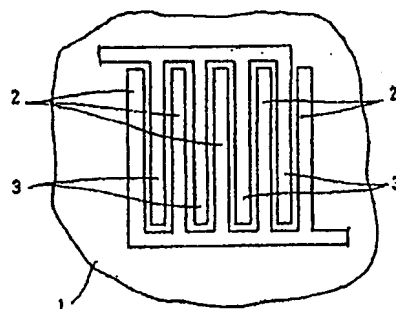

【图3】

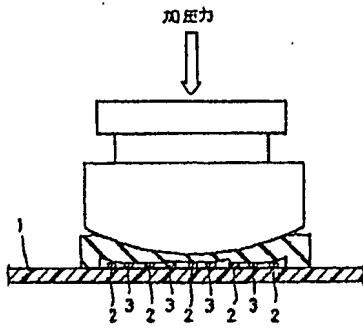

【图4】

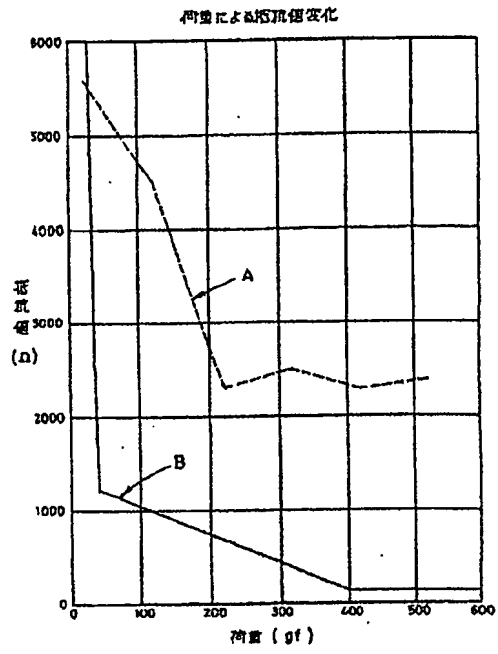

JAPANESE LAID-OPEN PATENT APPLICATION

H5-304007 (1993)

(19) Japan Patent Office (JP)	(11) Publication No.	H5-304007		
(12) Laid-Open Patent Application (A)	(43) Publication Date	November 16, 1993		
(51) Int. Cl. ⁵	Identification	In-House	FI	Place of Technical
	Code	Reference No.		Designation
H 01 C 10/10		A		
H 01 H 13/12			7250-5G	
13/52		Z	4235-5G	
	No examination request			Number of claims 1 (totally 4 pages)

(21) Application No.	PA H4-108250
(22) Date of Filing	April 28, 1992 (Heisei 4)
(71) Applicant	000158840 Kinugawa Rubber Industry Co., Ltd. 330, Naganuma-machi, Inage-ku Chiba-shi, Chiba-ken
(72) Inventor	Shiro TANAMI Kinugawa Rubber Industry Co., Ltd. 330, Naganuma-machi, Inage-ku Chiba-shi, Chiba-ken
(72) Inventor	Takashi IKEDA Kinugawa Rubber Industry Co., Ltd. 330, Naganuma-machi, Inage-ku Chiba-shi, Chiba-ken
(74) Agent	Fujiya SHIGA , Attorney (with other three persons)

Specification

(54) [Title of the Invention] Pressure Sensitive Switch

(57) [Abstract]

[Purpose] To suddenly lower the resistance value of pressure-sensitive conductive rubber by instantaneously applying a small pressure force.

[Constitution] Pressure-sensing conductive rubber 4 is formed in the cross-sectional shape of an inverted recess to make it easy to collapse. A switching operation between electrodes 2 and 3 is conducted by utilizing such a property that the electrical resistance of the pressure-sensitive conductive rubber 4 itself suddenly lowers while the contact area between the electrodes 2 and 3 increases with the collapse deformation of the pressure-sensitive conductive rubber 4.

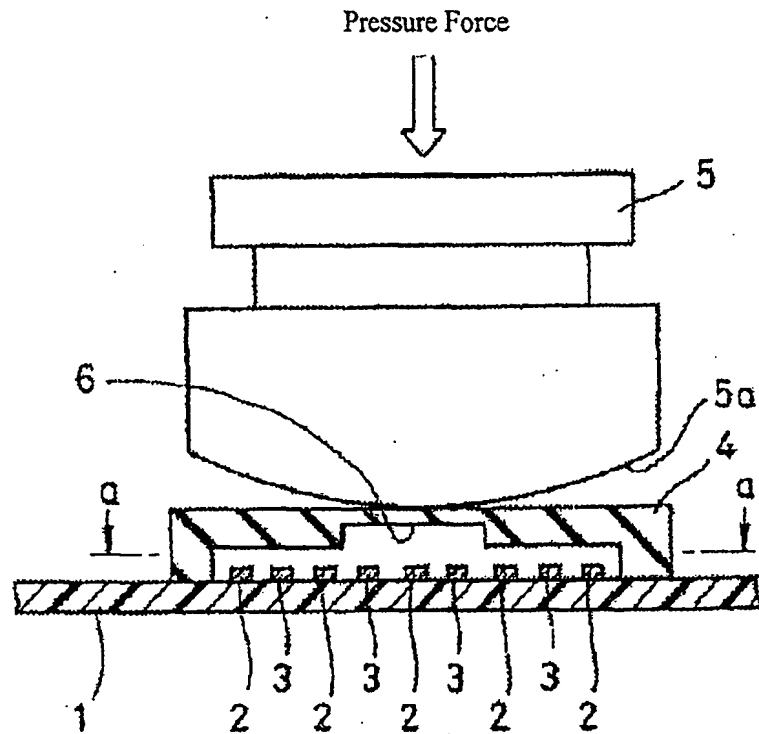

- 1 : printing board
- 2 : positive electrode
- 3 : negative electrode
- 4 : pressure-sensitive conductive rubber

[Claims]

[Claim 1] A pressure sensitive switch made by arranging pressure-sensitive conductive rubber on a board provided with at least one of a positive electrode and a negative electrode and accomplishes switching between one electrode and the other electrode with the pressure-sensitive conductive rubber as the center due to a resistance change accompanied by the compressive deformation of the pressure-sensitive conductive rubber itself, by pressurizing the pressure-sensitive conductive rubber and is characterized by forming the pressure-sensitive conductive rubber in the

cross-sectional shape of an inverted recess so that the pressure-sensitive conductive rubber and one electrode do not make contact in the non-pressure state of the pressure-sensitive conductive rubber.

[Detailed Description of the Invention]

[0001]

[Field of industrial application] The present invention relates to a pressure sensitive switch that accomplishes switching by use of a resistance change accompanied by the applied pressure of a pressure-sensitive conductive rubber.

[0002]

[Prior Art] As a pressure sensitive switch using a pressure-sensitive conductive rubber, for example, as shown in Japanese Laid-Open Patent Application 52-5477, it has been known that many hill-like projections are formed on the surface of one sheet electrode formed by a pressure-sensitive conductive rubber while the other sheet electrode made of a conductive cloth or the like is pasted to the surface of a sheet electrode formed with these projections. When both electrodes are pressurized, switching is accomplished between the electrodes is by use of the property that their electrical resistance is suddenly lowered by increasing the contact area between the two electrodes due to the compressive deformation of the projections.

[0003]

[Problem overcome by the invention] In the conventional pressure sensitive switch described above, if the applied pressure force is increased to some extent, there is a tendency for the resistance value of the pressure-sensitive conductive rubber to reduce, but the resistance value is not changed, remaining infinite under a very small applied pressure force and the initial applied pressure force necessary for switching relatively increases, which is undesirable.

[0004] In the conventional structure, when it is pressurized to a specific applied pressure force, even if its resistance value lowers, dropping of the resistance value, i.e., the degree of lowering of the resistance value accompanied by the applied pressure, is reduced, the lowering characteristic of resistance value is slowed, if the dispersion of the lowering characteristic is considered, its function as a pressure sensitive switch could not be fully displayed.

[0005] From such a perspective, a pressure sensitive switch of a structure in which the height of the projections is allowed to be alternately different to improve the lowering of above resistance

value has been proposed by the present applicant as Japanese Patent Application H3-234523. In this type of pressure sensitive switch, as shown by the broken line A in Fig. 4, a more sudden lowering characteristic is found, but it not only is insufficient in a drop from the beginning of lowering of the resistance value to its saturation at a specific value, but also the load change required to obtain the drop is bigger, and there is still a problem of practicability.

[0006] The present invention focuses on the problems described above and provides a structure that has a small initial applied pressure force and provides a larger drop in resistance value with a small change of applied pressure force.

[0007]

[Problem resolution means] The present invention is a pressure sensitive switch which arranges pressure-sensitive conductive rubber on a board provided with at least one of a positive electrode and a negative electrode and accomplishes switching between one electrode and the other electrode with the pressure-sensitive conductive rubber as the center due to the resistance change accompanied by the compressive deformation of the pressure-sensitive conductive rubber, by pressurizing the pressure-sensitive conductive rubber, and characteristically forms the pressure-sensitive conductive rubber in the cross-sectional shape of an inverted recess so that the pressure-sensitive conductive rubber and one electrode come into non-contact in the non-pressure state of the pressure-sensitive conductive rubber.

[0008]

[Function] According to this structure, the pressure-sensitive conductive rubber is made extremely easy to flex by making the pressure-sensitive conductive rubber in the cross-sectional shape of an inverted recess, and also conforms to a required characteristic of the pressure sensitive switch that the contact area with the electrodes be increased with pressurizing the pressure-sensitive conductive rubber to lower the resistance value. Accordingly, a larger contact area of the pressure-sensitive conductive rubber for the electrodes may be ensured, the resistance value is also suddenly lowered at a very small applied pressure force, eliminating the need to further increase the applied pressure force.

[0009]

[Example] Figs. 1 and 2 are diagrams showing an example of the present invention, and show an example applied to a keyboard switch.

[0010] As shown in Figs. 1 and 2, multiple positive electrodes 2 and multiple negative electrodes 3 are formed on a print board 1 in such a shape that they are made overall different from each other by pattern printing. A pressure-sensitive conductive rubber 4 is placed on the print board 1 so as to cover both the electrodes 2 and 3, and a key top 5 having an arc-like pressing surface 5a of a prescribed curvature is placed on the pressure-sensitive conductive rubber 4.

[0011] Then, the pressure-sensitive conductive rubber 4 is entirely formed in the cross-sectional shape of an inverted recess so that it does not make contact with the electrodes 2 and 3 in a non-pressure state, a depression 6 is formed at the center of the downside thereof, and the center of pressure-sensitive conductive rubber is formed into a thinner thickness.

[0012] Therefore, according to the structure of this example, if the pressure-sensing conductive rubber 4 is pressurized via the key top 5, as shown in Fig. 3, the pressure-sensitive conductive rubber 4 collapses instantaneously, and it comes into contact with at least one of multiple positive electrodes 2, 2 ... and one of multiple negative electrodes 3, 3

[0013] If the pressure-sensitive conductive rubber 4 collapses and becomes deformed as described above, not only do the positive electrode 2 and the negative electrode 3 simply conduct with the pressure-sensitive conductive rubber 4 as a movable contact, but also the electrical resistance of the pressure-sensing conductive rubber 4 is instantly lowered by increasing the contact area with the deformation of the pressure-sensitive conductive rubber 4, a necessary current flowing between the positive electrode 2 and the negative electrode 3 to accomplish switching.

[0014] The above example A solid line B of Fig. 4 shows the lowering characteristic of resistance value of the pressure-sensitive conductive rubber 4. The resistance value of the pressure-sensitive conductive rubber 4 is infinite in the non-pressure state, and in contrast, if pressure is applied, the resistance value suddenly lowers wherein, in a range in which the applied pressure force is about 30 ~ 40 gf, the lowering degree of the resistance value slows down at a greater applied pressure force, and gently lowers until it reaches an applied pressure force of about 400 gf, and the resistance value stabilizes at a resistance value close to zero and at an applied pressure force greater than 400 gf.

[0015] According to this example, the resistance value of pressure-sensing conductive rubber 4 is suddenly lowered by applying only a very small applied pressure force, markedly reducing the initial applied pressure force. Moreover, once the resistance value is lowered, a sufficient drop of resistance value necessary for switching is obtained without further increasing the applied pressure force.

[0016] Since the pressure-sensitive conductive rubber 4 has the cross-sectional shape of an inverted recess and becomes cavity-like in the non-pressure state, a moderate feeling in the switching is obtained by the collapse deformation of the pressure-sensitive conductive rubber 4.

[0017] An example of arranging both the plus and negative electrodes 2, 3 on the print board 1 is shown in the above embodiment example, but only one of either a positive or negative electrode may be arranged on the print board 1 and the other electrode may be arranged on the upper side of or within the pressure-sensitive conductive rubber 4.

[0018]

[Efficacy of the invention] According to the present invention as described above, the pressure-sensing conductive rubber is formed in the cross-sectional shape of an inverted recess when accomplishing switching due to a resistance change accompanied by the applied pressure of the pressure-sensitive conductive rubber with the pressure-sensitive conductive rubber as a movable contact, therefore the pressure-sensitive conductive rubber is easily collapsed and deformed, ensuring a large contact area in the collapse deformation, and a large drop of resistance value is instantaneously obtained by applying only a very small applied pressure, and once the resistance value starts to lower, additional pressure force need not be applied, greatly improving the sensitivity or responsiveness as a pressure sensitive switch.

[0019] Since a moderate feeling accompanied by the collapse deformation of the pressure-sensitive conductive rubber itself is also obtained when the pressure-sensitive conductive rubber is pressurized, the pressure sensitive switch also operates satisfactorily.

[Brief description of the drawings]

[Fig. 1] Sectional view at the time of no applied pressure showing an example of the present invention.

[Fig. 2] Sectional view along the a-a line of Fig. 1.

[Fig. 3] Sectional view of a pressure sensitive switch at the time of applied pressure showing an example of the present invention.

[Fig. 4] Characteristic diagram showing the relationship between the applied pressure force (load) and resistance value of the above pressure sensitive switch.

[Description of the symbols]

- 1: print board
- 2: positive electrode
- 3; negative electrode
- 4; pressure-sensitive conductive rubber
- 5; key top

[Fig. 1]

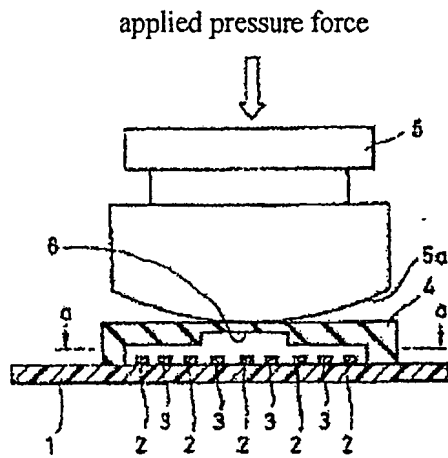

- 1: print board
- 2: positive electrode
- 3: negative electrode
- 4: pressure-sensitive conductive rubber

[Fig. 2]

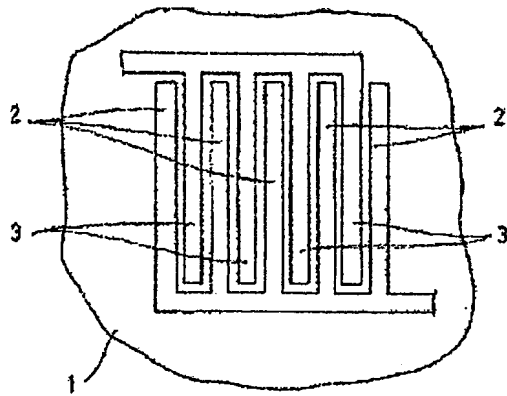

[Fig. 3]

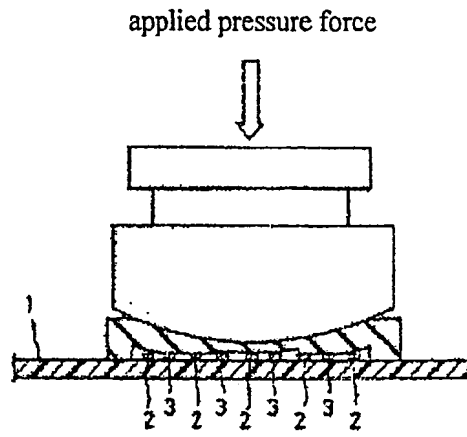

[Fig. 4]

Resistance value change with load

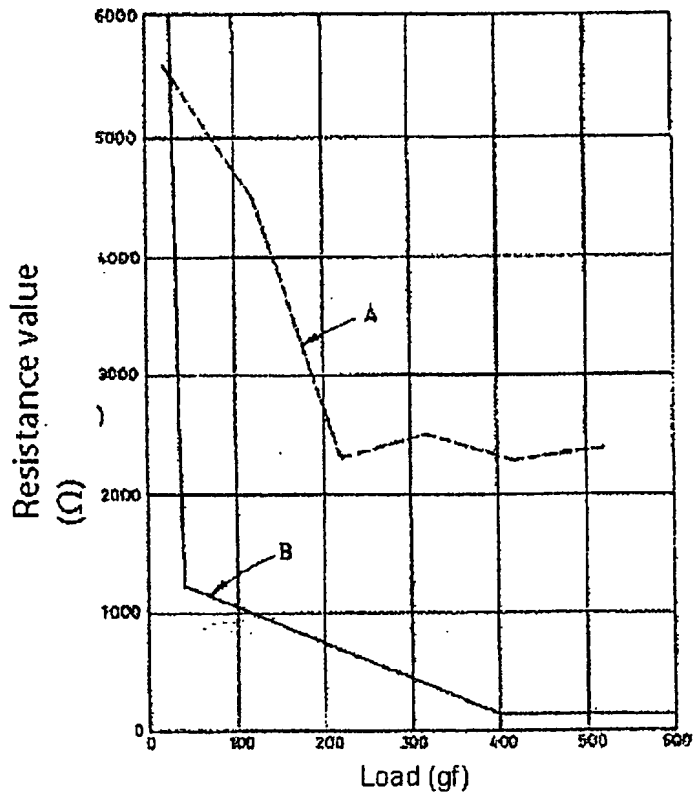

CERTIFICATE OF TRANSLATION

I Roger P. Lewis, whose address is 42 Bird Street North, Martinsburg WV 25405, declare and state the following:

I am well acquainted with the English and Japanese languages and have in the past translated numerous English/Japanese documents of legal and/or technical content.

I hereby certify that the Japanese translation of the attached translation of documents identified as:

Laid Open Patent Application

H5-304007

"Pressure Sensitive Switch"

is to the best of my knowledge and ability true and accurate.

I further declare that all statements contained herein of our own knowledge, are true, that all statements of information and belief are believed to be true.

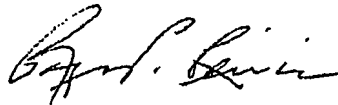

ROGER P. LEWIS

October 24, 2006



INTERNATIONAL APPLICATION PUBLISHED UNDER THE PATENT COOPERATION TREATY (PCT)

<p>(51) International Patent Classification ⁵ : H01H 13/70, H01C 10/10 H01H 1/10</p>	A1	<p>(11) International Publication Number: WO 92/02029 (43) International Publication Date: 6 February 1992 (06.02.92)</p>
<p>(21) International Application Number: PCT/US91/05077 (22) International Filing Date: 18 July 1991 (18.07.91) (30) Priority data: 557,546 24 July 1990 (24.07.90) US (71) Applicant: HOME ROW, INC. [US/US]; 9123 St. Helens Road, Suite 100, Post Office Box 889, Clackamas, OR 97015 (US). (72) Inventors: BRANDENBURG, Eric, L. ; 4059 SW Jefferson Parkway, Lake Oswego, OR 97035 (US). FRANZ, Patrick, J. ; 1849 SE 43rd Avenue, Portland, OR 97215 (US). STRAAYER, David, H. ; 23050 Highway 211, Colton, OR 97017 (US).</p>	<p>(74) Agents: STOLOWITZ, Micah, D. et al.; Marger, Johnson, McCollom & Stollowitz, Inc., 621 SW Morrison Street, Suite 650, Portland, OR 97205 (US). (81) Designated States: AT (European patent), BE (European patent), CA, CH (European patent), DE (European patent), DK (European patent), ES (European patent), FR (European patent), GB (European patent), GR (European patent), IT (European patent), JP, KR, LU (European patent), NL (European patent), SE (European patent). Published With international search report.</p>	
<p>(54) Title: KEYSWITCH-INTEGRATED POINTING ASSEMBLY</p>		
<p>(57) Abstract</p> <p>A keyswitch-integrated pointing assembly in which a plurality of substantially planar force sensing elements (24) are disposed on a planar surface (22) adjacent a keyswitch on a keyboard. The keyswitch includes a plunger (12) which extends downwardly from a key cap (10) for actuating a switch (32) at the lower end of vertical key cap travel. The key cap (10) engages an indexing surface (11) when fully depressed which transmits force applied to the key cap (10) to the force sensing elements (24). The force sensing elements (24) are sandwiched between a pair of opposing plates (20 and 30) thereby biasing the elements into a substantially linear operating region when no force is applied to the key cap (10).</p>		

FOR THE PURPOSES OF INFORMATION ONLY

Codes used to identify States party to the PCT on the front pages of pamphlets publishing international applications under the PCT.

AT	Austria	ES	Spain	MG	Madagascar
AU	Australia	FI	Finland	ML	Mali
BB	Barbados	FR	France	MN	Mongolia
BE	Belgium	GA	Gabon	MR	Mauritania
BF	Burkina Faso	GB	United Kingdom	MW	Malawi
BG	Bulgaria	GN	Guinea	NL	Netherlands
BJ	Benin	GR	Greece	NO	Norway
BR	Brazil	HU	Hungary	PL	Poland
CA	Canada	IT	Italy	RO	Romania
CF	Central African Republic	JP	Japan	SD	Sudan
CG	Congo	KP	Democratic People's Republic of Korea	SE	Sweden
CH	Switzerland	KR	Republic of Korea	SN	Senegal
CI	Côte d'Ivoire	LI	Liechtenstein	SU ⁺	Soviet Union
CM	Cameroon	LK	Sri Lanka	TD	Chad
CS	Czechoslovakia	LU	Luxembourg	TG	Togo
DE	Germany	MC	Monaco	US	United States of America
DK	Denmark				

⁺ It is not yet known for which States of the former Soviet Union any designation of the Soviet Union has effect.

KEYSWITCH-INTEGRATED POINTING ASSEMBLY**BACKGROUND OF THE INVENTION**

5

Field of the Invention

The present invention relates generally to apparatus for controlling cursor movement on a cathode ray tube (CRT) and more particularly to such apparatus which is integrated with a keyswitch on a keyboard.

10

Description of the Related Art

15

20

Prior art pointing devices for controlling a cursor on a CRT are known. What others have failed to appreciate is the ergonomic implications of mechanical and electrical null regions which must be traversed at the outset of a pointing operation. Using prior art devices, even those that are force-sensitive, a user gets no response to lateral displacement initially, until an electrode makes initial contact, for example, with an elastomeric resistive layer. The initial contact causes a step response, as resistance drops from infinity to a measurable value - a jump the user may not have anticipated or desired. Then, as force is increased, resistance falls rapidly, over some range, and finally falls more slowly with the application of additional force. All of this is disconcerting to a user for most applications. What is needed is to provide for pointing which is smoothly and consistently responsive to user input from the outset of the pointing operation.

25

30

Another disadvantage associated with prior art devices is that they are not sensitive to z-axis force. Forces applied laterally, i.e., in the x-y axis plane move the CRT cursor correspondingly. It would be desirable for a vertical force, e.g., down the shaft of a joystick-type controller, to produce a proportional signal. Such a signal could be used for example to control line width while drawing as a function of z-axis force on the pointing device.

Pointing devices which are integrated into keyswitches on keyboards are also known in the prior art. In addition to suffering from the above-described disadvantages associated with prior art pointing devices, such integrated devices take up substantially more space than a conventional key switch.

5

One prior art cursor control is shown in U.S. 4,313,113 (Thornburg). It employs four orthogonal variable resistance pressure transducers, each transducer comprising a coordinate electrode spaced from a cooperating electrode, at least one of the electrodes being an elastomeric sheet material formed of a carbon loaded polyolefin. The path resistance through the transducer goes down as applied pressure goes up. Thornburg recognizes the advantage of using force to control cursor speed. It makes no suggestion to integrate the device into a regular keyswitch. The electrodes are spaced from the elastomeric layer, at rest, so that there is a mechanical and electrical null region before the system responds to a force input, followed by a step response when the electrode layers make initial contact.

10

15

20

U.S. 4,439,648 (Reiner et al.) is directed to a basic stand-alone joystick. The handle rests on a rigid pivot so that vertical force is ignored. The handle is coupled to an actuator portion spaced from all four switches, so there is a neutral or null region of displacement before any switch is closed. The switches are conventional, yielding only a binary signal, without regard to force.

25

30

U.S. 4,408,103 (Smith, III) discloses a miniaturized joystick adapted for mounting in a wristwatch. The joystick handle rests in a hollowed-out bearing surface so that none of the switches is actuated by a downward force on the handle. The switch actuating means is maintained spaced from all the switches by a resilient rubber sheet layer, so there is a neutral or null region of displacement before any of the switches is closed. The switches are miniaturized by forming them as interleaved electrodes on a PCB. When the handle is pivoted, an actuator

pushes a conductive region of the resilient layer into contact with a corresponding switch. The switches each yield a binary output, so lateral force beyond an initial detent is ignored.

5 U.S. 4,246,452 (Chandler) shows another joystick type device, here having
16 possible output signals. The mechanism again employs a handle having a
depending member that rests in a hollowed out bearing surface. Once again, the
switches each provide a binary signal, independent of lateral force beyond a
threshold force; vertical force is ignored; and, the actuator is spaced from the
10 switches to provide a null region.

U.S. 4,680,577 (Straayer et al.) suggests a multipurpose cursor control
keyswitch that serves both as a regular typing key, preferably in the "home row"
(asdf-jkl;) of a keyboard, as well as a force-sensitive pointing input device. The
15 use of strain gauges as shown therein for force sensing, however, is not
commercially practical. Additionally, the recent rise in popularity of portable,
lap-top and now "notebook" computers makes low profile methods essential.

20 SUMMARY OF THE INVENTION

The present invention comprises a pointing device having a reference plate
and a generally planar force sensing means mounted on the reference plate. An
actuator applies force to said force sensing means. The actuator and force sensing
25 means are interconnected so that lateral and vertical forces applied to said
actuator are transmitted to said force sensing means.

In another aspect of the present invention, the pointing device is integrated
with a keyswitch on a keyboard.

30

It is a general object of the present invention to provide a keyswitch-integrated pointing assembly which overcomes the above-enumerated disadvantages associated with prior art devices.

5 It is another object of the present invention to provide such an assembly which smoothly distributes forces between sensing elements.

10 It is still another object of the present invention to provide such an assembly which moves the operating point of the force sensing elements into a continuous, smoother, region of operation.

15 It is yet another object of the present invention to provide such an assembly having generally opposed sensors which are loaded and unloaded in a complementary fashion.

It is another object of the present invention to provide such an assembly which is relatively low profile in structure and which is manufactured with relatively low dimensional tolerance sensitivity.

20 The foregoing and other objects, features and advantages of the invention will become more readily apparent from the following detailed description of preferred embodiments which proceeds with reference to the drawings.

25 BRIEF DESCRIPTION OF THE DRAWINGS

FIG. 1 is an exploded perspective view of a first embodiment of a elastomeric dome keyswitch and integrated pointing assembly according to the present invention.

30 FIG. 2 is a cross-sectional view taken along line 2-2 in FIG. 1.

FIG. 3 is an exploded perspective view of an alternative embodiment of a elastomeric dome keyswitch and integrated pointing assembly according to the present invention.

5

FIG. 4 is a cross-sectional view taken along line 4-4 in FIG. 3.

FIG. 5 is an exploded perspective view of a first embodiment of a discrete keyswitch and integrated pointing assembly according to the present invention.

10

FIG. 6 is a cross-sectional view taken along line 6-6 in FIG. 5.

FIG. 7 is an exploded perspective view of an alternative embodiment of a discrete keyswitch and integrated pointing assembly according to the present invention.

15

FIG. 8 is a cross-sectional view taken along line 8-8 in FIG. 7.

FIG. 9 is an exploded perspective view of an elastomeric dome keyswitch and integrated pointing assembly including a pre-load spring assembly according to the present invention.

20

FIG. 10 is a cross-sectional view taken along line 10-10 in FIG. 9.

FIG. 11 is a cross-sectional view similar to FIGS. 2 and 4 showing the preload means located beside the switch mechanism instead of above or below it.

25

FIG. 12 is a partially broken-away top view a keyboard, with the J keycap removed, showing a mechanism similar to that of FIGS. 1 and 2 having three force sensing areas instead of four.

30

FIG. 13 is a plot of the force versus resistance plot for an FSR* force sensing resistor.

5

DETAILED DESCRIPTION OF THE PREFERRED EMBODIMENTS

FIG. 1 is an exploded perspective view of a first embodiment of an elastomeric keyswitch and integrated pointing assembly according to the present invention. Beginning roughly in the middle of the diagram, a conventional elastomeric type keyboard includes a base plate 30, such being also referred to herein as a reference plate, which is generally planar. The base plate may be of any suitable rigid material, such as a plastic or metal, or it may be a printed circuit board. For many applications, the base plate 30 is a printed circuit board and it includes a plurality of switch contacts 32, like contacts 32, formed on the printed circuit board so that switch closure is effected by downward pressure on the switch contacts. This type of keyswitch is commonly used in a computer keyboard, in which an array of such switch contacts are formed on the base plate in a predetermined pattern corresponding to the pattern of the typing keys.

20

A conventional elastomeric keyboard also includes a rubber dome sheet 20. The rubber dome sheet includes an array of dome springs, like dome spring 21, which provide a spring action that biases the keyswitch to the standby open position. The rubber dome sheet 20 is registered over the base plate 30 so that each dome spring 21 is aligned over a respective one of the switch contacts 32. In some designs, the switch contacts 32 on the base plate comprise an interleaved set of conductive fingers. In that case, the underside of the dome spring 21 includes a conductive pad which, when pressed against the interleaved fingers, completes an electrical path between the fingers thereby closing the switch.

25
30

Alternatively, in a membrane type keyswitch, the switch may comprise a vertically spaced pair of electrodes in which case the underside of dome spring 21 need not be conductive, but merely arranged to impart vertical force to close the switch. A plunger guide 14 rests on top of the rubber dome sheet 20. The rubber dome sheet is silicone with a 30-50 Shore "A" durometer. The plunger guide 14 includes a central aperture 16, further discussed below. The plunger guide 14 is positioned with the aperture 16 aligned over the dome spring 21 and switch contacts 32. In the present embodiment of the invention, plunger guide 14 is polycarbonate. The plunger guide 14 also includes a tower portion 15 extending about the periphery of aperture 16. The tower portion 15 includes an upper surface 18, hereafter referred to as the actuator indexing surface.

A conventional key cap 10 is coupled to a plunger 12. In some cases, the key cap and plunger are molded of a single part, and in other cases they may be formed of separate parts and engage one another. The aperture 16 is sized to fittingly engage the plunger 12 while allowing vertical sliding motion of the plunger responsive to a vertical force applied to the key cap by an operator.

A force-sensing resistor array 22 is positioned between the base plate 30 and rubber dome sheet 20. The force-sensing resistor array 22 includes a central aperture 28, sized to clear the plunger 12 and switch contacts 32. The array 22 is positioned so that the aperture 28 is registered with the plunger guide aperture 16, dome spring 21 and switch contacts 32. In a typing mode of using the apparatus, a generally downward pressure is applied to the key cap 10 by an operator. The key cap and plunger 12 move downward together, with the plunger sliding through the plunger guide aperture 16. The bottom end of the plunger contacts dome spring 21 and compresses the dome sheet so that the underside of the dome spring 21 contacts the switch contacts 32 on the base plate. Accordingly, the force-sensing resistor array 22 does not interfere with, or in any way affect, the usual operation of the keyswitch.

Vertical travel of the key cap and plunger is limited to a position in which the key cap indexing surface 11 contacts the actuator indexing surface 18. The key cap indexing surface 11 and actuator indexing surface 18 have complementary configurations for mating with one another. They may simply be flat, for example, or they may be tapered, stepped, or the like, to aid in guiding the plunger and to contribute to a solid coupling between the key cap and plunger, on the one hand, and the plunger guide/actuator 14 on the other hand, when the key cap is in a depressed state.

A pre-load pad 34 is positioned in parallel contact with the underside of base plate 30. A rigid back-up plate 36 is positioned in parallel contact with the underside of pre-load pad 34. The back-up plate 36, pre-load pad 34, base plate 30, force-sensing resistor array 22, and rubber dome sheet 20, all have a plurality of mounting holes, preferably arranged symmetrically about the neutral axis. The neutral axis, as used herein, refers to a vertical axis through the center of apertures 16, 28, dome spring 21, etc. in FIGS. 1 and 2 and to a corresponding central axis in each of the other embodiments. The plunger guide/actuator 14 includes corresponding mounting holes, at least extending into the underside of the plunger guides/actuator, for receiving fastening means such as fasteners or screws 38. The screws 38 extend through the back-up plate, pre-load pad, base plate, force-sensing resistor array, rubber dome and rubber dome sheet and are threadably secured in the plunger guide/actuator for maintaining the foregoing elements in the positions described. As can be seen in Fig. 2, the bores in plates 30, 36; pad 34; array 22; and sheet 20 through which screws 38 extend are sized to leave an annular space as shown between the shaft of each screw 38 and the bores through which it is received. With the end of each screw threadably secured in guide/actuator 14, the guide/actuator may thus be rocked or tilted about the neutral axis in a manner and for a purpose which is described in more detail hereinafter. The fasteners 38 could be integrally formed with the back-up plate 36 or guide/actuator 14.

Operation of the elastomer key switch and integrated pointing assembly of FIG. 1 is best understood with reference to a cross-sectional view of the same assembly shown in FIG. 2. FIG. 2 shows the assembly of FIG. 1 in the standby state, i.e., when no external force is applied to the key cap 10. This cross-sectional view illustrates a flat configuration of the indexing surfaces 11, 18.

The actuator 14 includes four actuator surfaces 17, protruding from the underside of actuator 14 and positioned so that each of the actuator surfaces 17 contacts a respective one of the force-sensing resistor elements 24 in the array 22. Preferably each of actuator surfaces 17 are substantially in the shape of a spherical segment. The rubber dome sheet 20 extends between the actuator surfaces 17 and the corresponding force-sensing elements 24. This has been found to be advantageous in that the rubber dome sheet smoothly disperses or distributes forces applied through the actuator surfaces 17 to the force-sensing element 24. The base plate 30 provides a relatively rigid support to the underside of the force-sensing array 22 so that forces applied through the actuator surfaces 17 are efficiently coupled to the force-sensing array. The actuator 14 includes a hollowed out portion on the underside, defined by a surface 19, so that the actuator 14 does not contact the dome spring 21. The actuator therefore does not interfere with the usual typing operation.

The height of the tower portion 15 of the actuator is sized to cooperate with the key cap and plunger to limit vertical displacement of the keycap and plunger to a position sufficient to actuate switch contacts 32, but no further. Once the indexing surfaces 11, 18 are contacting one another, substantially all forces applied to the key cap by an operator, vertical as well as lateral, are transmitted through the plunger and actuator to the force sensor array.

As noted with regard to FIG. 1, the actuator 14 is coupled to the back-up plate 36 by suitable rigid fasteners 38. The pre-load pad 34, extending between the back-up plate 36 and the base plate 30 is formed of a compressible material such as a closed cell foam. In the present embodiment of the invention, plate 30 comprises a polyurethane foam with a low compression set. During manufacture, the fastening means are applied so as to partially compress the pre-load pad 34. This arrangement holds the entire assembly together without play and, more particularly, applies a pre-load force to each of the force-sensing elements 24.

Applying a pre-load force to the force-sensing resistor elements 24 is important for the following reasons. First, force-sensing resistor elements, for example a device sold under the trade name FSR* by Interlink, Inc. of California, provide essentially infinite resistance when no force is applied to the element. When even small initial force is applied, on the order of a hundred grams, the FSR* elements instantly drop to an initial resistance on the order of a few hundred thousand ohms. This drastic change, or step response, is disconcerting to an operator and undesirable for most applications. The application of a pre-load force to the FSR* device eliminates this initial step response problem.

Second, even after a small initial force is applied, FSR* elements exhibit resistance to force characteristics that initially changes very quickly, for example, exponentially, and, as force is further increased, moves into a more linear region of operation. By arranging a pre-load force to bias the FSR* elements into this more linear region of operation, the devices will exhibit a more linear response to external forces applied by the operator.

It may be observed that the key cap 10 is entirely supported by the structures shown in FIG. 2. In a conventional keyboard, the key cap and plunger

are supported by a plunger guide having a central aperture similar to aperture 16 in actuator 14, but the guide generally is part of a continuous molded plate that includes a guide for each of the key switches in a keyboard array. Here, the plunger guide is formed in the actuator 14, which must be isolated from the rest of the keyswitch array to provide for imparting lateral forces for pointing operations. The structure shown in FIG. 2, therefore, is freestanding, except that it is mounted on the base plate or printed circuit board 30.

In normal keyswitch operation, as noted, the pointing device apparatus does not affect the switch operation. The tactile response or "feel" of the keyswitch is the same as an unmodified keyswitch, in that it is determined by the usual dome spring 21 on the rubber dome sheet 20. In a pointing operation, the indexing surfaces 11, 18 contact each other so that all forces imparted to the key cap 10 by an operator are transmitted to the actuator 14 and, through the actuator surfaces 17, to the force-sensing array 22. As noted above the force-sensing elements are pre-loaded to a predetermined operating point, so that a lateral force applied to the key cap 10, for example, along the X or Y axis, results in a differential signal in that the force applied to one of the force-sensing elements 24 is increased while the force applied to the force-sensing element opposite the first force-sensing element is decreased. A force applied in any direction off the X or Y axis results in resistance to change in all four sensing elements.

Noteworthy is the absence of any pivot type supporting means as in a conventional joystick. According to the present invention, the keycap and plunger are supported, in the depressed state, by the actuator 14. Accordingly, downward or Z direction forces are coupled through the actuator surfaces 17 to the sensing array 22. The present apparatus thereby measures the overall or net force applied by an operator. The net force can easily be computed by summing the forces on all the sensors. The net applied force information is useful in many applications, for example, to control cursor speed, or to provide Z axis control.

Increasing the apparent cursor speed in response to a greater operator applied force provides a natural and ergonomically efficient response.

5 The pre-load pad 34 also affords the advantage of neutralizing manufacturing variations in the various components described, as well as obviating a pivot's high tolerance requirements. In use, the compressed pre-load pad 34 takes up variations in thickness of the elements in between the backup plate 36 and the actuator 14 to avoid any play or wobble in the system. As long as the force-sensing elements are biased to some reasonable operating point, a
10 processing unit coupled to the force-sensing array can be arranged to calibrate itself to define zero force as whatever resistances are provided by the force-sensing elements in the absence of externally applied forces.

15 Elimination of the pivot type supporting means also allows the present invention to avoid interference with the operation of the existing keyswitch means.

20 FIG. 3 is an exploded perspective view of an alternative embodiment of an elastomer keyswitch and integrated pointing assembly according to the present invention. Referring to FIG. 3, the assembly again includes a base plate 30, a force-sensing array 22, rubber dome sheet 20, keycap 10, and plunger 12, all of which are similar to those described with regard to FIGS. 1 and 2. Here, the existing keyboard or other device is assumed to include a fixed top plate 40. The top plate 40 may be part of a larger plate that forms part of a keyboard array or,
25 for example, may be part of a rigid enclosure. Plate 40 includes a central aperture 42 which is sized to provide clearance around the guide tower 47 to allow lateral displacement of the tower. For some applications, in which the existing aperture 42 is sized to fittingly engage the plunger for guiding the plunger, it must be suitably enlarged for implementing the integrated pointing assembly. A
30 combined plunger guide and actuator 46 (hereafter "actuator") is positioned, as

before, to rest on the existing rubber dome sheet 20, albeit without contacting the dome spring portion 21. Actuator 46 includes a central aperture 49 sized to fittingly engage the plunger 12 while allowing sliding motion of the plunger responsive to the vertical depression of the keycap. The actuator 46 also includes
5 a tower portion 47 extending about a periphery of the aperture 49 and including an actuator indexing surface 48 for contacting a complementary keycap indexing surface 11 (shown in FIG. 4) on the underside of the keycap.

A preload means 44, in this case a foam pre-load pad, includes a central
10 aperture 45 sized to clear the tower 47 so that the pre-load pad 44 rests on the peripheral flange portion of actuator 46.

FIG. 4 is a cross-sectional view of the assembly of FIG. 3 in a standby position, i.e., in the absence of externally applied forces. Actuator 46 includes a
15 hollowed out portion on the underside so that it does not contact the dome spring 21. The actuator 46 includes actuator surfaces 50 protruding from the underside of the actuator, each of which is positioned over a respective one of the force sensor elements 24.

20 As before, the rubber dome sheet 20 extends between the actuator surfaces 50 and the corresponding force sensor elements for distributing applied forces. As noted, the aperture 42 in support plate 40 provides a space 42 between the actuator 46 and support plate 40 extending around the entire periphery of the aperture 42, so that, even when a lateral force is applied to deflect the keycap and
25 plunger off the neutral axis, the actuator does not contact the support plate 40. The pre-load pad 44 is positioned between the peripheral flange portion of the actuator 46 and the underside of support plate 40.

In the typical keyboard application, the support plate 40 is fixed to the base plate 30, independently of the structures here described. For example, a typical keyboard may have screws or other fasteners interconnecting top and bottom plates at several locations. Such an arrangement may be adequate to hold the structures of FIGS. 3 and 4 in their intended positions. However, it may be preferable, depending upon the particular application, to provide fastening means for interconnecting the support plate 40 to the base plate 30 in one or more locations adjacent the integrated assembly of FIGS. 3 and 4 to ensure appropriate pre-loading of the force-sensing elements as described above. This is illustrated in FIG. 3 as fastener 41. Although the pre-loading pad is arranged differently in the embodiment of FIGS. 3 and 4, it functions essentially in the same manner and provides the same advantages as described above with respect to FIGS. 1 and 2.

FIG. 5 is an exploded perspective view of a first embodiment of a discrete keyswitch and integrated pointing assembly according to the present invention. The term "discrete keyswitch" is used here to refer to any of a variety of switches which are self-contained to stand alone. That is, the discrete switch includes some switch mechanism disposed within a housing and having a plurality of leads extending from the housing for electrical connection to the switch. This is distinguished from an elastomer keyswitch of the type described above which is implemented in some elastomer or arranged on a printed circuit board. FIG. 5 thus includes a switch mechanism housing 56 that encloses a conventional switch.

An existing base plate (or printed circuit board) 64 includes mounting holes 65 and a plurality of clearance holes 68, sized to clear leads (in FIG. 6) that extend from the underside of the switch housing 56.

Force-sensing array 22, keycap 10 and plunger 12 are similar to those described above. The switch mechanism housing 56 which, in general, is a cube-shape, is modified to include an actuator flange 58 extending about a periphery of

the housing as shown. The combined unit is referred to hereafter as a switch/actuator 72. Switch/actuator 72 includes a central aperture 57 sized to fittingly engage the plunger 12 while allowing a vertical sliding motion therein.

5 The switch/actuator 72 also includes a switch/actuator indexing surface 70 extending along a periphery of aperture 57 for contacting the keycap indexing surface 11 as described above. A compliant force distribution pad 60 is sized and shaped to fit between the sensor array 22 and switch/actuator 72, and, more particularly, to cover the force sensing elements 24. Pad 60 is made from a
10 material similar to rubber dome sheet 20. The force distribution pad 60 includes a central aperture 61 sized and arranged to clear a bottom portion of the switch/actuator 72, as best seen in FIG. 6. The force distribution pad is formed of a resilient, compliant material such as a foam or rubber material, for distributing forces applied by the switch/actuator 72 over a surface area of the force-sensing
15 elements 24, similar to the rubber dome sheet 20 in the embodiments described above.

 A pre-load pad 54 is arranged to rest on an upper surface of the actuator flange 58 and includes a central aperture 55 sized to clear the switch mechanism
20 housing 56. Finally, a pressure plate 52 is sized to at least cover the pre-load pad 54 and similarly includes a central aperture 53 sized to clear the switch mechanism housing 56. A plurality of fasteners 66, for example screws, are disposed to extend through or from the base plate 64, through elements 22, 60, 58 and 54, and are secured into holes 51 provided in the pressure plate 52 for that
25 purpose. The arrangement of the mounting holes is not critical, although preferably they are symmetrically arranged about the neutral axis to pre-load the force-sensing elements evenly. Where the force-sensor elements 24 are arranged in a square configuration, as shown in FIG. 5, it is convenient to provide the mounting holes in a square configuration rotationally offset by 45° from the
30 square defined by the force-sensor elements, as illustrated.

Referring to FIG. 6, the assembly of FIG. 5 is shown in cross-section in the standby state. As the switch/actuator 72 includes four actuator surfaces 59, each of which protrudes from the underside of the actuator flange region 58 and is registered with a respective one of the force-sensing elements 24. Spring 75 is a schematic depiction of a conventional biasing element which biases plunger 12 upwardly. The compliant force pad 60 extends between the actuator surfaces 59 and the force-sensing elements 24 to distribute forces transmitted by the actuator surfaces. The pre-load pad 54 and pressure plate 52, as noted, include central apertures sized to clear the switch mechanism housing 56, thereby providing a clearance gap 73 therebetween, to allow lateral deflection of the keycap and plunger, when plunger 12 is fully depressed relative to actuator 72, without contacting the pressure plate or pre-load pad. The base plate 64 is fastened to the pressure plate 52 to compress the pre-load pad 54, thereby applying a pre-load force to the force-sensing elements as discussed earlier.

Importantly, the switch/actuator 72 is arranged so that a bottom surface 74 of the switch housing 56 is spaced from the base plate 64, thereby forming a gap 78 therebetween.

The switch leads 80 extend through clearance holes 68 in the base plate and are electrically connected, for example, to the underside of base plate 64 (in the case in which the base plate is a printed circuit board) by flexible leads 82 so that there is essentially no mechanical coupling between the switch leads 80 and the base plate. Accordingly, the switch/actuator 72 rests on, and is mechanically supported only by, the actuator surfaces 59. Thus, when the keycap 10 is depressed toward the base plate so that the keycap indexing surface 11 contacts the actuator indexing surface 70, all forces applied to the keycap 10 by an operator, including downward or Z axis forces, are transmitted through elements 72, 59, and 60 to the force-sensor array 22. The clearance gap 78 is sized to allow

adequate lateral deflections of the keycap and plunger while maintaining the bottom surface 74 spaced from the base plate 64. The configuration shown and described has no impact on the overall height of the keyswitch assembly, with the exception of the small gap 78. This is particularly advantageous in applications where the height profile is critical, such as keyboards in lap-top or "notebook" size computers.

FIG. 7 is an exploded perspective view of an alternative embodiment of a discrete keyswitch and integrated pointing assembly according to the present invention.

FIG. 8 is a cross-sectional view of the assembly of FIG. 7, shown in the standby state. The reader is by now familiar with the elements shown in FIGS. 7 and 8. Accordingly, this embodiment will be described only by way of comparison to the embodiment of FIGS. 5 and 6. In the embodiment of FIGS. 7 and 8, the pre-load pad 54 and pressure plate 52 are positioned below the base plate 64, i.e., on a side of the base plate opposite the switch/actuator 72. The assembly is otherwise similar to the earlier embodiment and functions essentially in the same way. While this embodiment extends slightly below the base plate 64, it has the advantage of providing clearance above the actuator flange 58. This allows the keycap 10 to extend down into the region over the actuator flange 58 as required in some very low-profile switch configurations.

FIGS. 9 and 10 illustrate yet another embodiment of the present invention, again directed to applications that include elastomeric dome or membrane keyswitches as discussed above with respect to FIGS. 1-4. Referring to FIGS. 9 and 10, the base plate 30, sensor array 22, rubber dome sheet 20, guide/actuator 46, keycap 10 and plunger 12 are similar to those described above. Here, however, a pre-load spring assembly 84 is provided for pre-loading the four sensor elements. The pre-load spring assembly 84 is formed of a sturdy yet

resilient material such as stainless steel 302 or PH 17-7. The pre-load spring assembly includes a frame portion 85 which is arranged to reside above an upper surface of the peripheral flange region of the actuator 46. The frame region 85 thus includes a central aperture 90, sized to clear the tower 47 of actuator 46.

5 Frame portion 85 also includes four depending regions 87, arranged to extend in use alongside the actuator 46. Each of the depending members 87 is formed to include a respective retaining clip 88 adjacent a terminal end of the corresponding depending member. The pre-load spring assembly 84 also includes a pair of spring elements 86, each extending generally coplanar to the frame region 85.

10 The terminal portions of each spring element 86 define a pair of ears 89, each ear extending downward below the plane defined by the frame region 85. The ears 89 contact the guide/actuator 46 at points 91.

The rubber dome sheet 20 includes four elongate slots 94 extending

15 therethrough for receiving a respective one of the depending members 87. Similarly, the base plate 30 includes four elongate slots 95 also for receiving the depending members 87. The depending members are spaced apart sufficiently to avoid contacting the sensor array 22.

20 Referring now to FIG. 10, the mechanism is assembled so that the pre-load assembly 84 is disposed about the actuator 46 so that each of the ears 89 contacts an upper surface of the peripheral flange region of the actuator 46. Each of the depending members 87 extends down alongside the actuator 46 and through the corresponding slots 94 in the rubber dome sheet 20 and the slots 95 in base

25 plate 30. The retaining clips 88 contact the lower surface of base plate 30 so as to retain the pre-load spring assembly 84 in position. The spring elements 86 exert downward pressure through the ears 89 on the actuator 46 to pre-load the force-sensing elements. The embodiment of FIGS. 9 and 10 is otherwise similar to the embodiments discussed above with respect to FIGS. 13 and 4. The pre-load

30 spring assembly 84 has the advantage of providing both the pre-loading means

and all necessary fasteners within a single integral unit. The spring assembly can be stamped out of a suitable metal and the necessary slots in the other elements can easily be stamped as well, resulting in simple and inexpensive manufacturing.

5 FIG. 11 illustrates yet another embodiment of the invention. While FIG. 4 illustrates a pre-load pad 44 disposed generally above an existing switch element, and FIG. 2 illustrates a pre-load pad 34 disposed below the existing switch element, FIG. 11 illustrates an embodiment in which pre-load pads 104 are disposed beside an existing switch element. Guide/Actuator 96 is substantially
10 similar to those in FIGS. 2 and 4 with the addition of a preload flange 106 disposed just outside the region containing the curved actuator surfaces 110. Top surface 97 and preload plate 102 are separated from keyboard top plate 98 by a gap 112. Fasteners 108 retain the preload plate 102 to the base plate 30 while compressing pads 104 and flange 106 therebetween. A clearance gap 114 is
15 provided so the actuator 96 can be rocked without binding. Gap 100 allows the actuator 96 to be displaced laterally without contacting top plate 98.

 FIG. 12 is a partially broken-away plan view of a keyboard 116 having a plurality of keycaps, like keycaps 118. In arrangement, the system shown is
20 similar to that in FIG. 1.

 The keycap and plunger are removed from the "J" key in Fig. 12 to show important aspects of the present invention more clearly. Actuator/guide 120 is shown beneath top plate 133 through a cutaway view in the top plate.
25

 Actuator/Guide 120 (hereinafter referred to as actuator 120) is similar to actuator 14 in FIG. 1 except that an alternative embodiment is shown using three force-sensing elements 122, denoted by dotted lines to indicate their location on the underside of the actuator 120, rather than four force-sensing elements, like elements 24 in Fig. 1. FIG. 12 shows the sensing elements 122 evenly spaced
30

around a central aperture 130 of actuator 120. Furthermore, one of the sensing elements is preferably lined up with a major axis (in this case the Y axis), reducing the complexity of the computations required to derive XY signals from the sensor information.

5

A rubber dome 126 is shown indicated by a dotted line below an actuator indexing surface 132. The tower portion of actuator 120 is separated from the clearance hole 128 in top plate 133 by a working gap, as in the previous figures. Fastener attachment holes 124 are located midway between the sensing areas and allow fasteners to attach the actuator 120 to the preload means beneath the base plate (not shown) as in FIG. 1.

10

FIG. 13 is a graph of the response of the example FSR force sensing means. FSRs change resistance dependent upon the force.

15

Graph 134 shows this resistance versus force relationship. For forces below 50 grams or so the FSR array is essentially an open circuit. As the force is increased from 10 to 100 grams or so, the resistance drops suddenly as indicated by region 136. Region 136 is characterized by highly variable operation and is not useful for accurate or repeatable force sensing.

20

As the applied force is increased further, to 200 grams or so, the resistance changes stabilize as indicated by region 138. Region 140, denoted by the heavy line, represents the useful operating range of the FSR array, from approximately 200 to 450 grams.

25

One purpose of the preload means of the present invention is to provide a constant force of approximately 300 grams on each of the FSR sensing elements. This both moves the FSR operating point into a more linear, repeatable region and allows forces on the actuator to both increase (as an actuator bears down) or

30

decrease (as an actuator lifts) forces on the FSR within it's useful range.

5 This latter effect of the preload means is very important, as it eliminates the need for a central pivot to distribute forces since the force sensors can now indicate reduced as well as increased loading. As forces are increased above 700 grams or so, the change in FSR resistance per additional gram lowers thus resulting in decreased sensitivity.

10 Having illustrated and described the principles of our invention in a preferred embodiment thereof, it should be readily apparent to those skilled in the art that the invention can be modified in arrangement and detail without departing from such principles. We claim all modifications coming within the spirit and scope of the accompanying claims.

CLAIMS:

1. A pointing device comprising:
a plate;
generally planar force sensing means, disposed in parallel contact with the reference plate and having a plurality of force sensing elements positioned in a predetermined pattern, for sensing force applied to the sensing elements;
actuator means disposed adjacent the force sensing means and having a plurality of actuator surfaces protruding toward the force sensing means, each of the actuator surfaces contacting a respective one of the force sensing elements for supporting the actuator means and for transmitting to the corresponding force sensing element a force applied to the actuator means;
means interconnecting the reference plate and the actuator means for maintaining the actuator surfaces in contact with the corresponding force sensing elements; and
means for pre-loading the force sensing elements so that each force sensing element provides a respective predetermined output signal in the absence of an external force applied to the keycap.
2. A pointing device according to claim 1 further comprising:
compliant means extending between the actuator surfaces and the force sensing elements for distributing the forces transmitted by the actuator surfaces.
3. A pointing device according to claim 1 wherein each actuator surface is convex along a region that contacts the corresponding force sensing element to apply force over a changing surface area of the sensing element responsive to changing force applied by the operator.

4. A pointing device according to claim 1 wherein the reference plate comprises a membrane substrate and the force sensing means is integrally formed in the substrate.

5. A pointing device according to claim 1 wherein the pre-loading means comprises:

a backup plate extending parallel to the reference plate on a side opposite the force sensing means; and

a pre-loading pad extending between the backup plate and the reference plate; and wherein the interconnecting means couples the backup plate to the actuator means, thereby maintaining the pre-loading force on the sensing means.

6. A pointing device according to claim 1 wherein each of the force sensing elements includes a force sensitive resistor means.

7. A pointing device according to claim 1 wherein said means for applying force comprises .

8. A pointing device according to claim 7 wherein:
the reference plate includes a switch;

the keycap includes a depending plunger having a bottom end for actuating the switch and a keycap indexing surface extending along an underside of the keycap;

the force sensing means includes a first central aperture sized to clear the plunger and registered over the switch;

the force sensing elements are positioned about the first central aperture;

the actuator means includes a second central aperture registered over the switch, sized to fittingly receive the plunger for transmitting lateral force to the actuator means, while allowing sliding motion therebetween for actuating the switch;

the actuator surfaces are positioned about the second central aperture; and the actuator means further includes an actuator indexing surface about the periphery of the second aperture for contacting the keycap indexing surface, when the keycap is depressed toward the reference plate, to transmit to the force sensing elements a Z component of a force applied to the keycap while the indexing surfaces contact one another.

9. A pointing device according to claim 1 wherein the pre-loading means comprises a spring assembly for biasing the pre-loading means into a pre-loaded condition.

10. A pointing device according to claim 1 wherein the actuator means and the keycap are supported primarily by the force sensing elements through the actuator surfaces so that external force, including X, Y and Z components thereof, is transmitted to the force sensing means.

11. A pointing device comprising:
a reference plate;
generally planar force sensing means mounted on said reference plate;
actuator means for applying a force to said force sensing means;
means for interconnecting said force sensing means and said actuator means whereby lateral and vertical forces applied to said actuator means are transmitted to said force sensing means.

12. The pointing device of claim 11 wherein said actuator means comprises a plurality of substantially semispherical segments having spherical portions thereof urged against said force sensing means and wherein said interconnecting means comprises:

a compressable pad adjacent a side of said semispherical segments substantially opposite said force sensing means; and

fastening means for urging said pad against said segments, said fastening means being constructed and arranged to permit a decrease in force applied to said sensing means by one of said spherical portions responsive to an increase in force applied to said sensing means by another of said spherical portions.

13. The pointing device of claim 11 wherein said device further includes means for pre-loading said force sensing means.

1/13

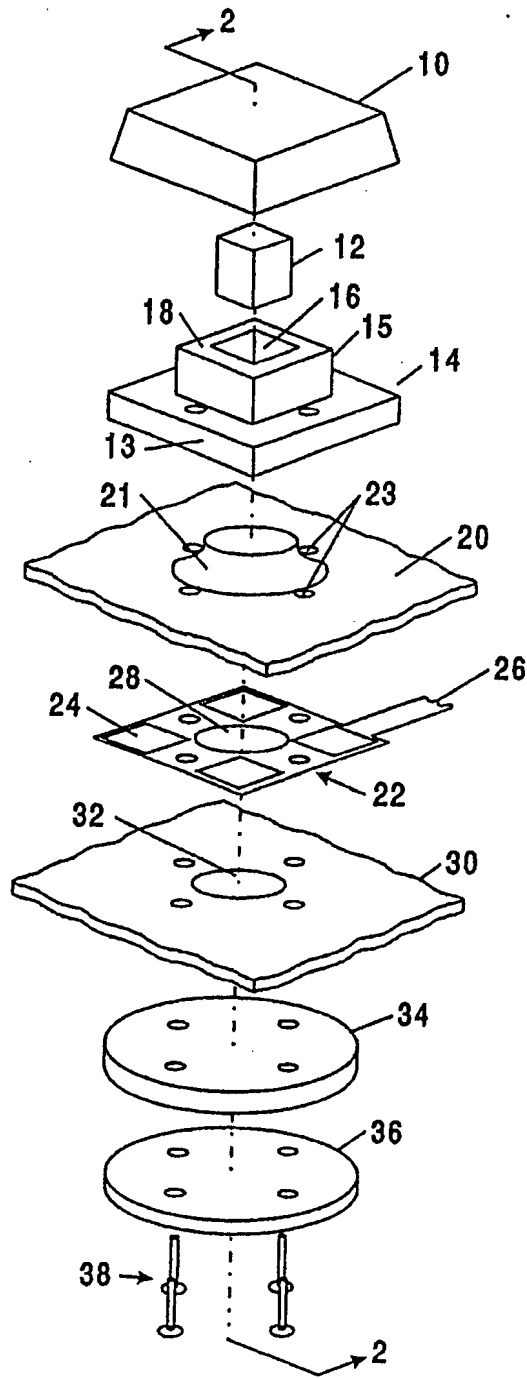

Figure 1

SUBSTITUTE SHEET

2/13

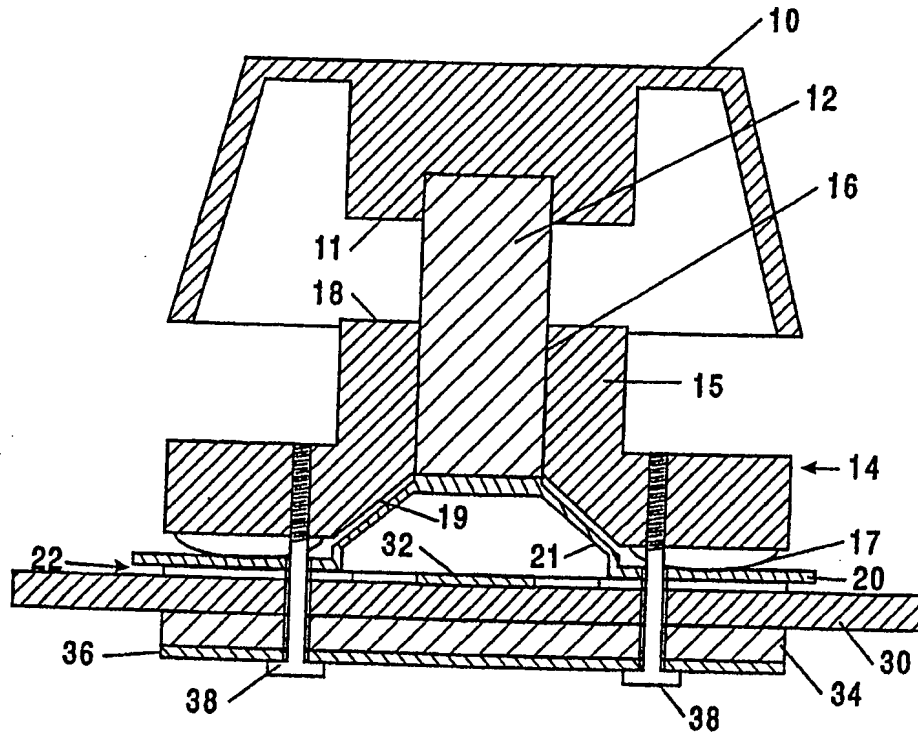

Figure 2

SUBSTITUTE SHEET

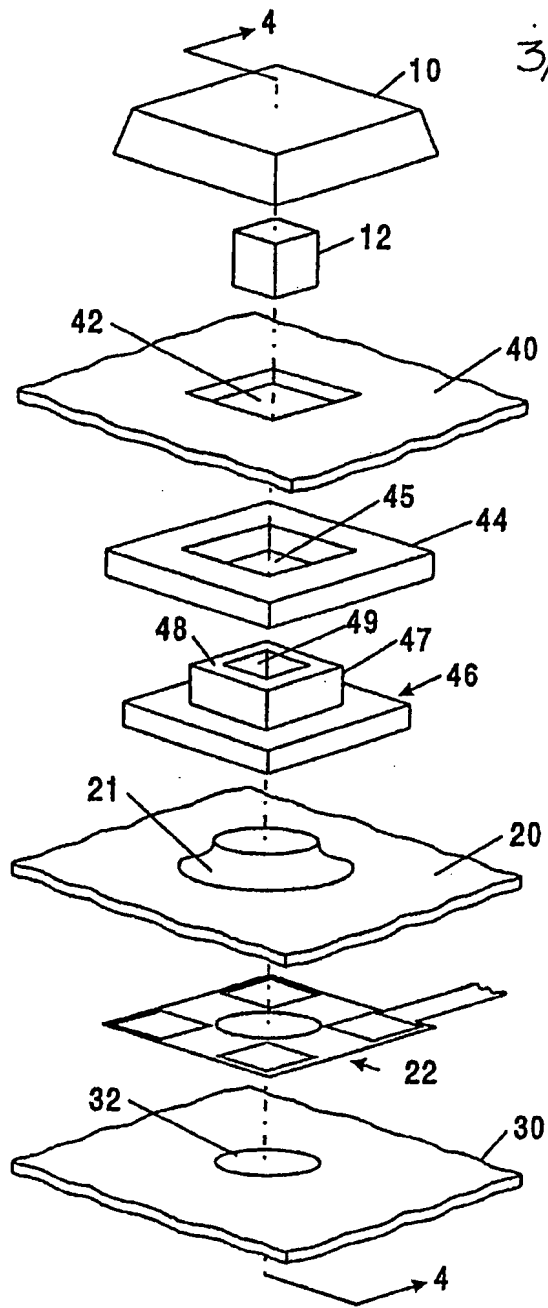

Figure 3

SIIBCTITITE SUFFP

4/13

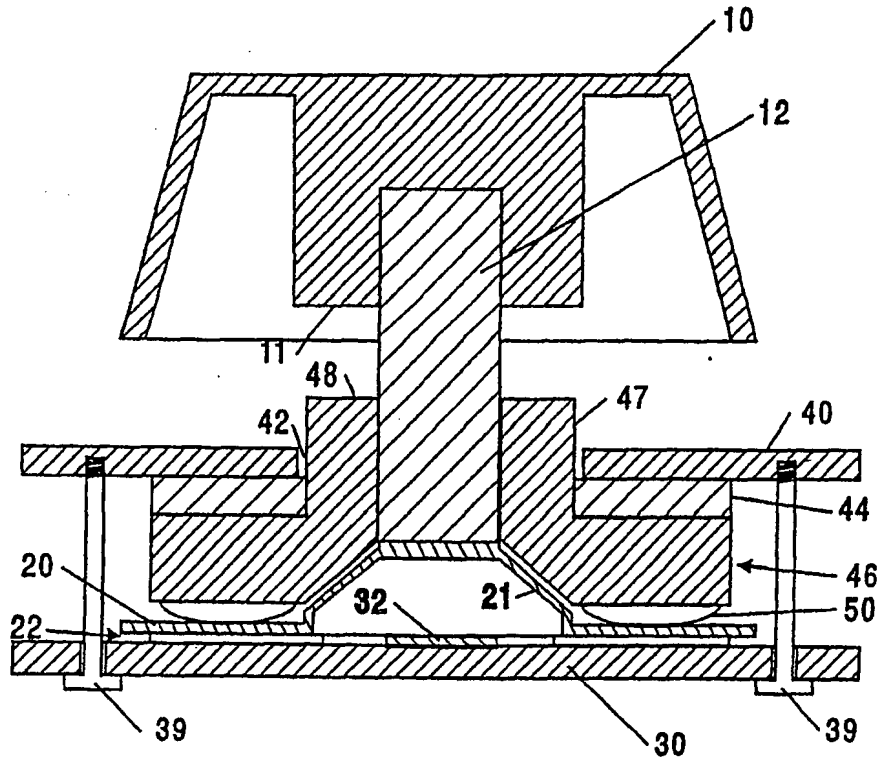

Figure 4

SUBSTITUTE SHEET

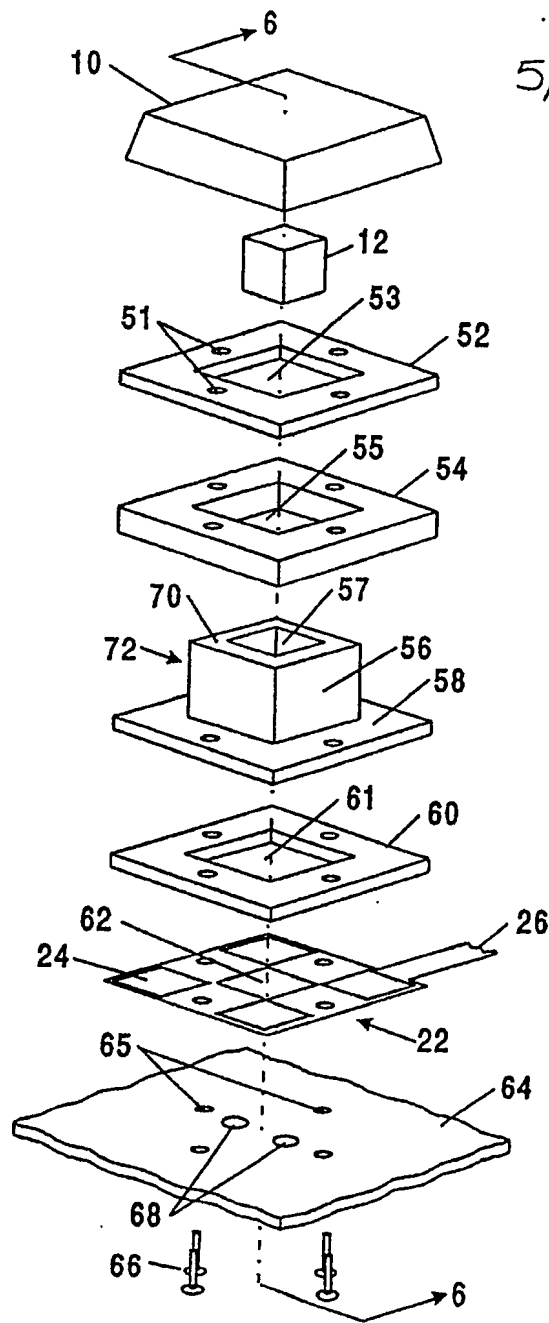

Figure 5

SUBSTITUTE SHEET

6/13

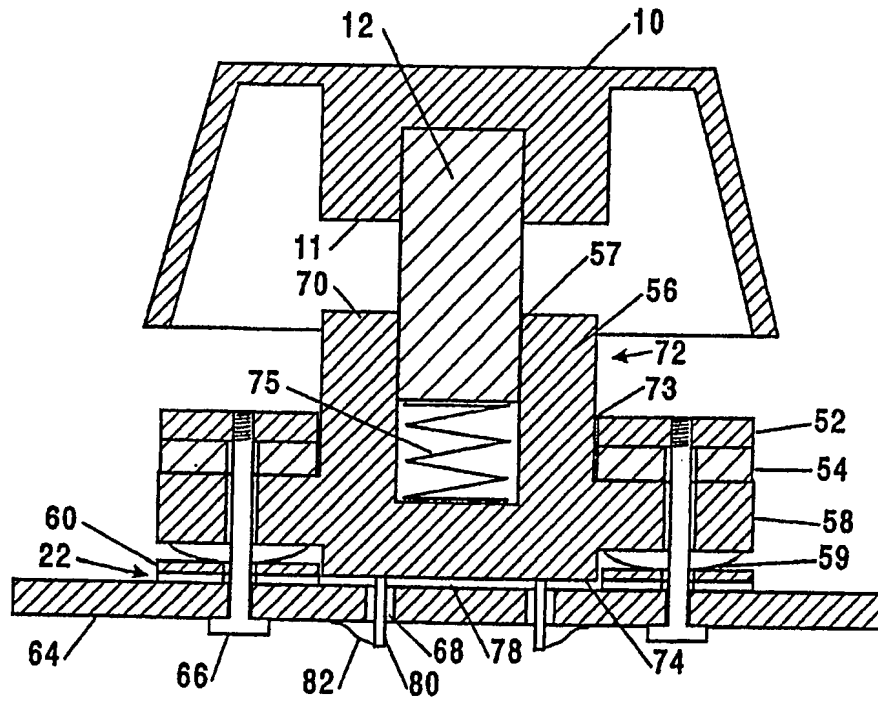

Figure 6

SUBSTITUTE SHEET

7/13

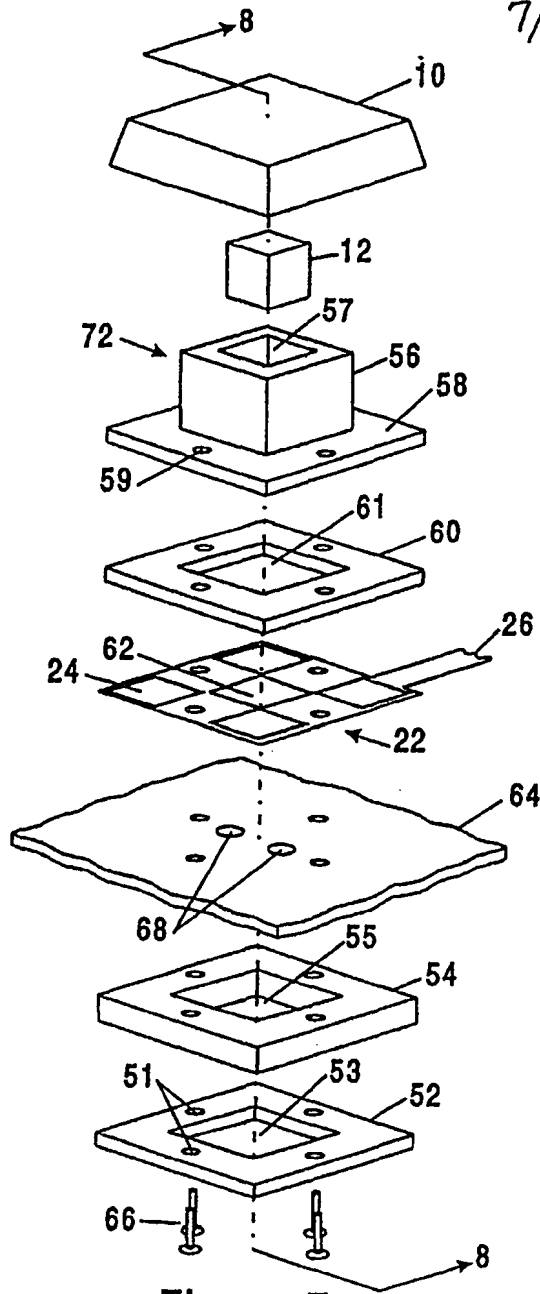

Figure 7

SUBSTITUTE SHEET

8/13

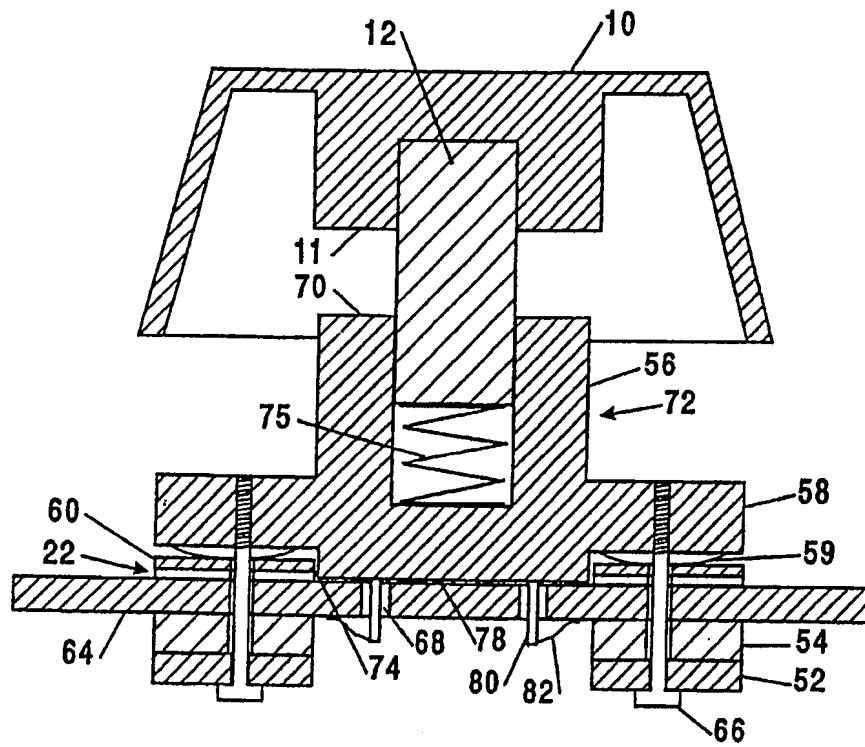

Figure 8

SUBSTITUTE SHEET

9/13

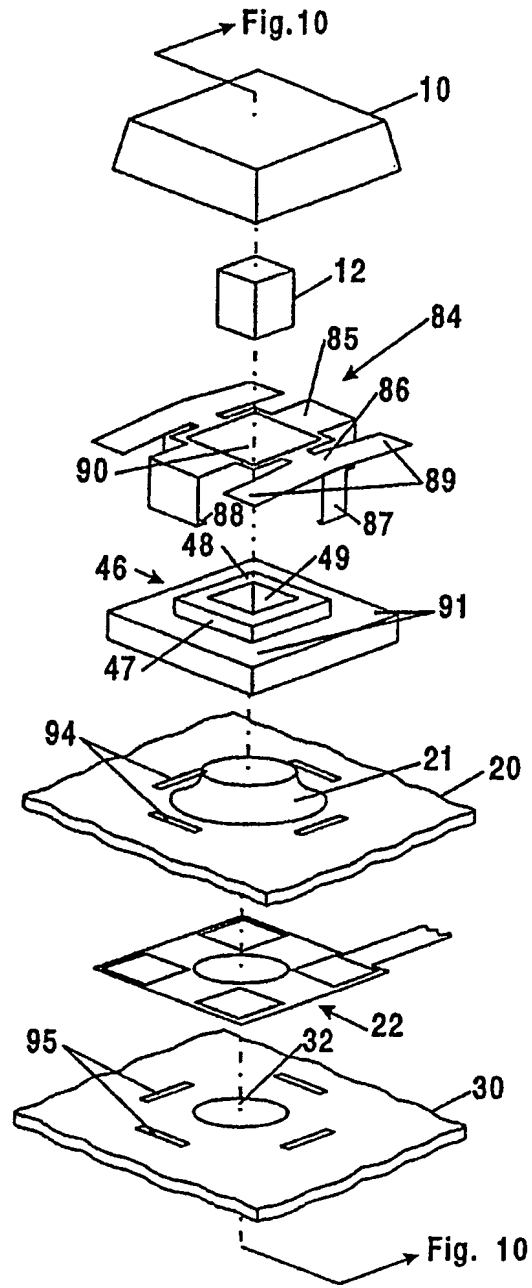

Figure 9

SUBSTITUTE SHEET

10/13

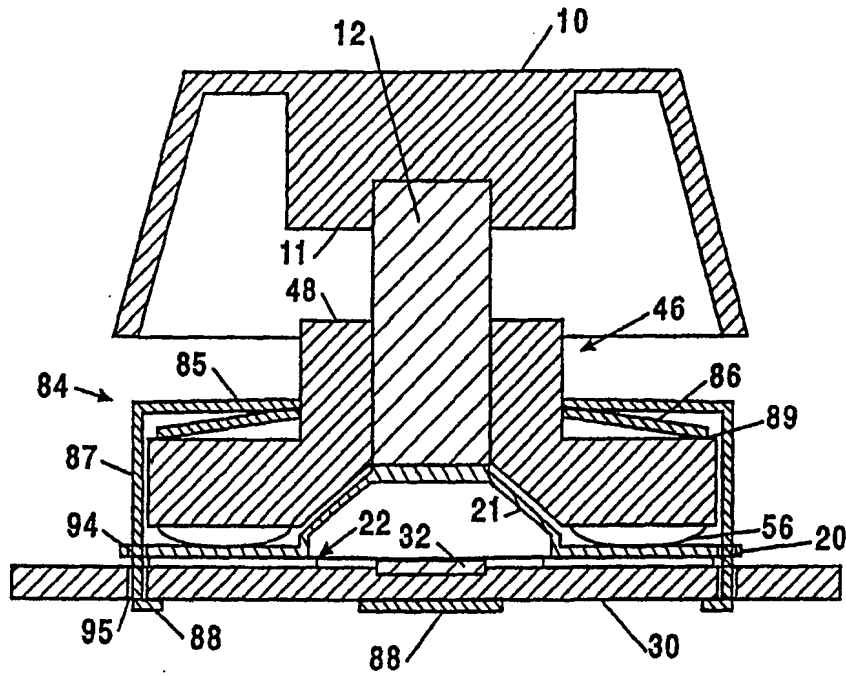

Figure 10

11/13

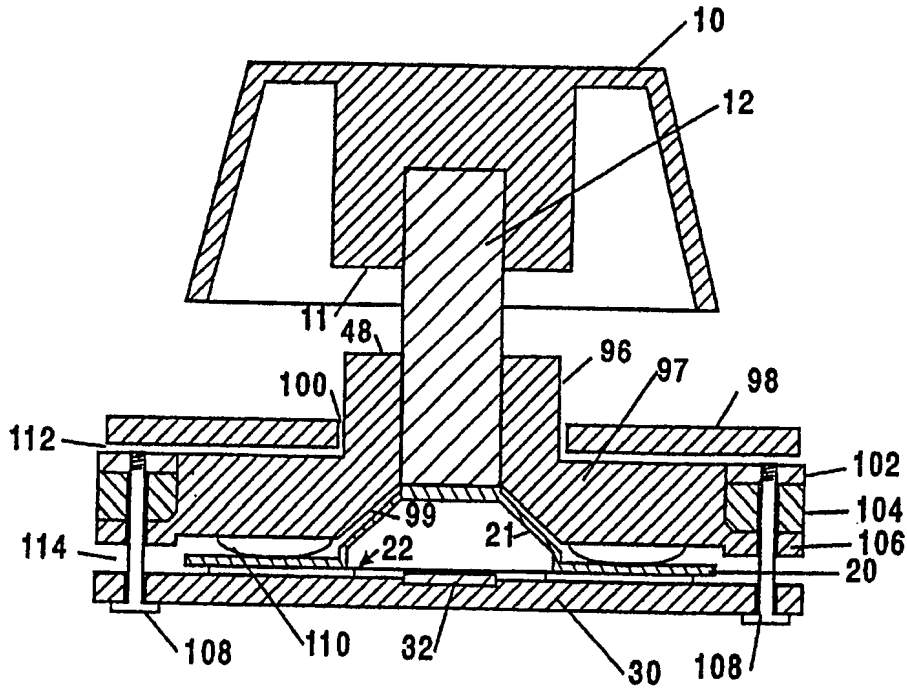

Figure 11

SUBSTITUTE SHEET

12/13

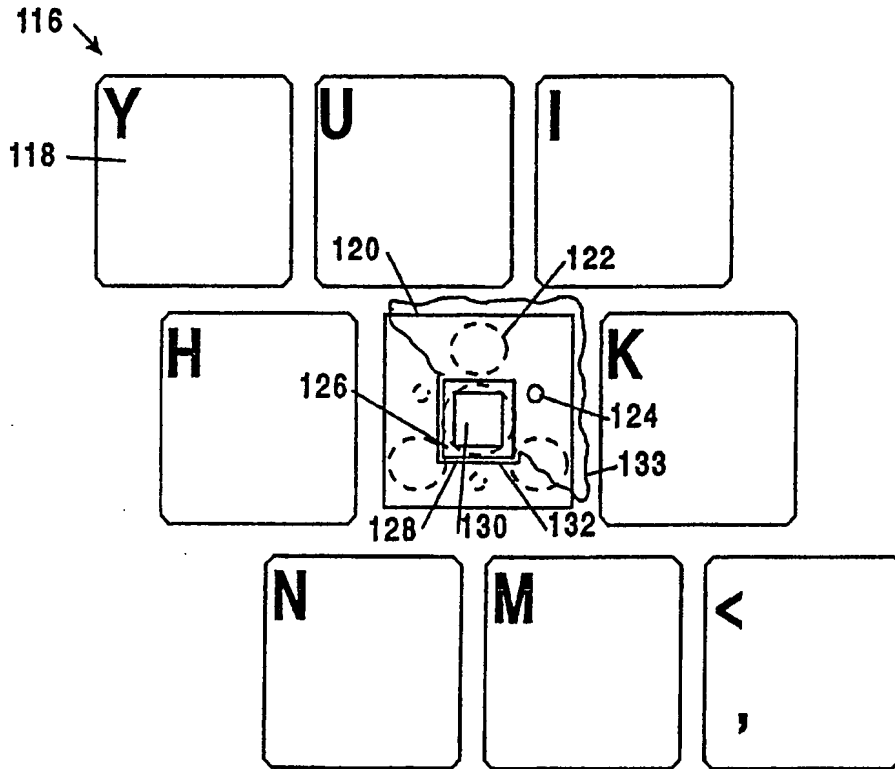

Figure 12

SUBSTITUTE SHEET

13/13

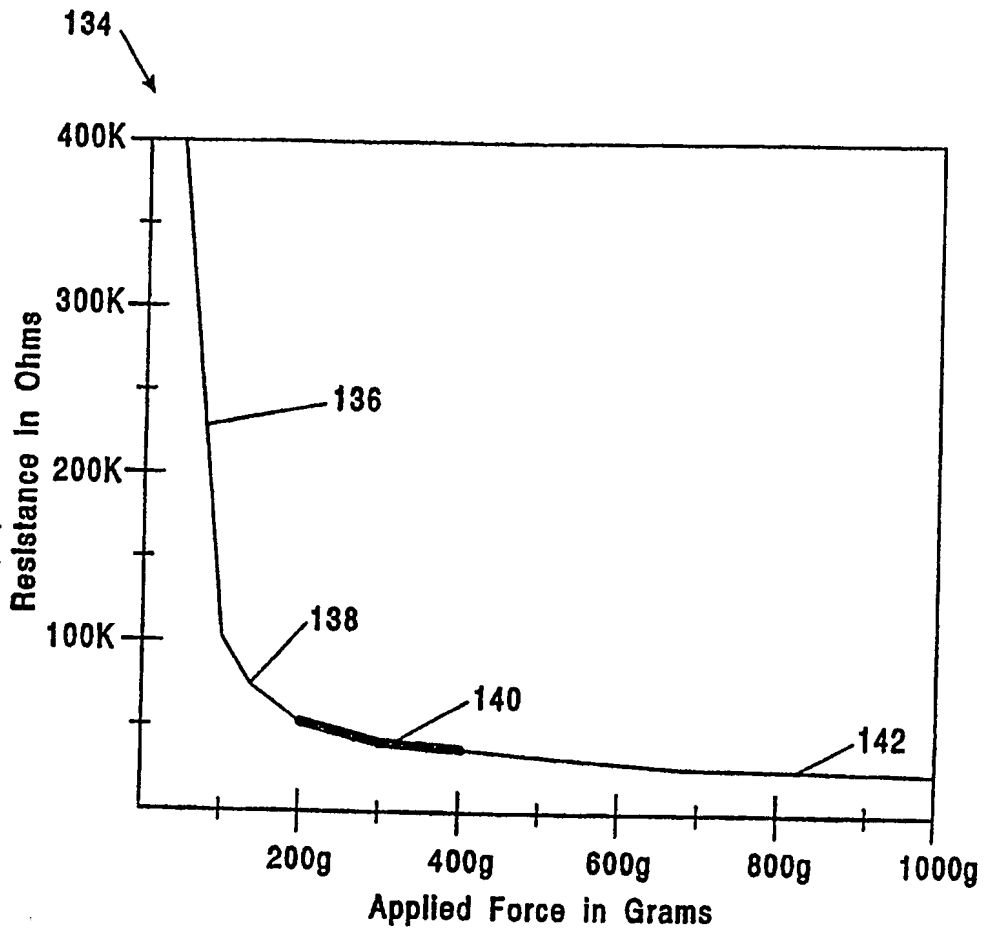

Figure 13

SUBSTITUTE SHEET

INTERNATIONAL SEARCH REPORT

International Application No. **PCT/US91/05077**

I. CLASSIFICATION OF SUBJECT MATTER (if several classification symbols apply, indicate all) ⁶		
According to International Patent Classification (IPC) or to both National Classification and IPC		
IPC(5): H01H 13/70 H01C 10/10 H01H 1/10 US CL: 200/5A 338/114 200/513		
II. FIELDS SEARCHED		
Minimum Documentation Searched ⁷		
Classification System	Classification Symbols	
US	200/5A; 5EA; 5R; 16A,B,C; 453,455;457,458,510,511,513,515,516 338/99,128,114 400/485,491	
Documentation Searched other than Minimum Documentation to the Extent that such Documents are Included in the Fields Searched ⁸		
III. DOCUMENTS CONSIDERED TO BE RELEVANT ⁹		
Category ⁹	Citation of Document, ¹¹ with indication, where appropriate, of the relevant passages ¹²	Relevant to Claim No. ¹³
Y	US, A, 4,029,915 (OJIMA) 14 JUNE 1977 See column 4, lines 1-44 and figure 6 and 8.	1-7,9-13
Y	US, A, 4,163,204 (SADO ET AL) 31 JULY 1979 See column 7, line 41 to column 8 line 7; column 8 lines 7-16 and figure 11.	1-2,4-7 11-13
Y	US, A, 4,851,626 (NAGASHIMA) 25 JULY 1989 See column 3, lines 54-59; column 3 lines 63-64 and figures 2 and 3.	8
<p>¹⁰ Special categories of cited documents:</p> <p>"A" document defining the general state of the art which is not considered to be of particular relevance</p> <p>"E" earlier document but published on or after the international filing date</p> <p>"L" document which may throw doubts on priority claim(s) or which is cited to establish the publication date of another citation or other special reason (as specified)</p> <p>"O" document referring to an oral disclosure, use, exhibition or other means</p> <p>"P" document published prior to the international filing date but later than the priority date claimed</p> <p>"T" later document published after the international filing date or priority date and not in conflict with the application but cited to understand the principle or theory underlying the invention</p> <p>"X" document of particular relevance; the claimed invention cannot be considered novel or cannot be considered to involve an inventive step</p> <p>"Y" document of particular relevance; the claimed invention cannot be considered to involve an inventive step when the document is combined with one or more other such documents, such combination being obvious to a person skilled in the art.</p> <p>"A" document member of the same patent family</p>		
IV. CERTIFICATION		
Date of the Actual Completion of the International Search	Date of Mailing of this International Search Report	
03 OCTOBER 1991	04 NOV 1991	
International Searching Authority	Signature of Authorized Officer	
ISA/US	<i>Steve Saras</i> STEVE SARAS	

Form PCT/ISA/210 (second sheet) (Rev.11-87)